



# Manual

## ELCO FS200

### IM FS2-GW-DP00

Order No.: ELCO FS2-GW-DP00

This manual is part of the documentation package  
with order number ELCO FS200\_IM and relevant for:

Product	Order number	as of state: HW	FW
IM FS200	FS2-GW-DP00	01	2.03

The information contained in this manual is supplied without warranties. The information is subject to change without notice.

© Copyright 2011, ELCO(Tianjin)ELECTRONIC CO.,LTD.  
No.12,4th XEDA Branch Road,Xiqing Economic Development Area,  
Tianjin 300385,P.R.China  
Tel.: +86 (22) 23888288/23788282  
Fax.: +86 (22) 23788399  
EMail: sales@elco.cn  
<http://www.elco-holding.com.cn>  
**Hotline:+86 (22) 23788282**

All rights reserved

**Disclaimer of liability**

The contents of this manual were verified with respect to the hard- and software.

However, we assume no responsibility for any discrepancies or errors. The information in this manual is verified on a regular basis and any required corrections will be included in subsequent editions.

Suggestions for improvement are always welcome.

**Trademarks**

ELCO and FS200  
are registered trademarks of ELCO(Tianjin)ELECTRONICS CO.,LTD.

SPEED7

is a registered trademark of profichip GmbH

SIMATIC, STEP and S7-300

are registered trademarks of Siemens AG.

Any other trademarks referred to in the text are the trademarks of the respective owner and we acknowledge their registration.

## About this manual

This manual describes the FS200 bus coupler for Profibus DP of the System intelligent I/O from ELCO. Here you may find every information for commissioning and operation.

### Overview

#### **Chapter 1: Basics and Assembly**

The focus of this chapter is on the introduction of the ELCO Intelligent I/O FS200. Here you will find the information required to assemble and wire a controller system consisting of System FS200 components. Besides the dimensions the general technical data of System FS200 will be found.

#### **Chapter 2: Hardware description**

Here the hardware components of the FS200 are more described. You will find the technical data at the end of this chapter.

#### **Chapter 3: Deployment**

This chapter describes the usage of the FS200 with Profibus. After a short introduction you may find here every information about assembly, project engineering and diagnostic. The chapter closes with the description of the firmware update.

# Contents

<b>User considerations</b> .....	<b>1</b>
<b>Safety information</b> .....	<b>2</b>
<b>Chapter 1 Basics and Assembly</b> .....	<b>1-1</b>
Safety Information for Users.....	1-2
System conception.....	1-3
Dimensions .....	1-6
Installation.....	1-7
Wiring.....	1-11
Installation guidelines .....	1-14
General data .....	1-17
<b>Chapter 2 Hardware description</b> .....	<b>2-1</b>
Properties.....	2-2
Structure .....	2-3
Technical data.....	2-6
<b>Chapter 3 Deployment</b> .....	<b>3-1</b>
Basics .....	3-2
Project engineering .....	3-10
DP-V1 services .....	3-13
DP-V1 - I&M data .....	3-15
Profibus installation guidelines .....	3-17
Diagnostic functions .....	3-20
Firmware update .....	3-28



## User considerations

**Objective and contents** This manual describes the FS2-GW-DP00 of the Intelligent I/O from ELCO. It contains a description of the structure, project engineering and deployment.

**Target audience** The manual is targeted at users who have a background in automation technology.

**Structure of the manual** The manual consists of chapters. Every chapter provides a self-contained description of a specific topic.

**Guide to the document** The following guides are available in the manual:

- an overall table of contents at the beginning of the manual
- an overview of the topics for every chapter

**Availability** The manual is available in:

- printed form, on paper
- in electronic form as PDF-file (Adobe Acrobat Reader)

**Icons Headings** Important passages in the text are highlighted by following icons and headings:



**Danger!**  
Immediate or likely danger.  
Personal injury is possible.



**Attention!**  
Damages to property is likely if these warnings are not heeded.



**Note!**  
Supplementary information and useful tips.

## Safety information

### Applications conforming with specifications

The Intelligent I/O FS200 is constructed and produced for:

- communication and process control
- general control and automation applications
- industrial applications
- operation within the environmental conditions specified in the technical data
- installation into a cubicle



### **Danger!**

This device is not certified for applications in

- in explosive environments (EX-zone)

### Documentation

The manual must be available to all personnel in the

- project design department
- installation department
- commissioning
- operation



**The following conditions must be met before using or commissioning the components described in this manual:**

- Modification to the process control system should only be carried out when the system has been disconnected from power!
- Installation and modifications only by properly trained personnel
- The national rules and regulations of the respective country must be satisfied (installation, safety, EMC ...)

### Disposal

**National rules and regulations apply to the disposal of the unit!**

# Chapter 1 Basics and Assembly

**Overview** The focus of this chapter is on the introduction of the ELCO FS200. Here you will find the information required to assemble and wire a controller system consisting of FS200 components. Besides the dimensions the general technical data of FS200 will be found.

Content	Topic	Page
	<b>Chapter 1 Basics and Assembly .....</b>	<b>1-1</b>
	Safety Information for Users.....	1-2
	System conception.....	1-3
	Dimensions .....	1-6
	Installation.....	1-7
	Wiring.....	1-11
	Installation guidelines.....	1-14
	General data .....	1-17



## Safety Information for Users

### Handling of electrostatic sensitive modules

ELCO modules make use of highly integrated components in MOS-Technology. These components are extremely sensitive to over-voltages that can occur during electrostatic discharges.

The following symbol is attached to modules that can be destroyed by electrostatic discharges.



The Symbol is located on the module, the module rack or on packing material and it indicates the presence of electrostatic sensitive equipment.

It is possible that electrostatic sensitive equipment is destroyed by energies and voltages that are far less than the human threshold of perception. These voltages can occur where persons do not discharge themselves before handling electrostatic sensitive modules and they can damage components thereby, causing the module to become inoperable or unusable.

Modules that have been damaged by electrostatic discharges can fail after a temperature change, mechanical shock or changes in the electrical load.

Only the consequent implementation of protection devices and meticulous attention to the applicable rules and regulations for handling the respective equipment can prevent failures of electrostatic sensitive modules.

### Shipping of modules

Modules must be shipped in the original packing material.

### Measurements and alterations on electrostatic sensitive modules

When you are conducting measurements on electrostatic sensitive modules you should take the following precautions:

- Floating instruments must be discharged before use.
- Instruments must be grounded.

Modifying electrostatic sensitive modules you should only use soldering irons with grounded tips.



### Attention!

Personnel and instruments should be grounded when working on electrostatic sensitive modules.

## System conception

### Overview

ELCO FS200 is a modular automation system for assembly on a 35mm mounting rail. By means of the peripheral modules with 2, 4 or 8 channels this system may properly be adapted matching to your automation tasks.

The wiring complexity is low, because the supply of the DC 24V power section is integrated to the backplane bus and defective modules may be replaced with standing wiring.

By deployment of the power modules in contrasting colors within the system, further isolated areas may be defined for the DC 24V power section supply.

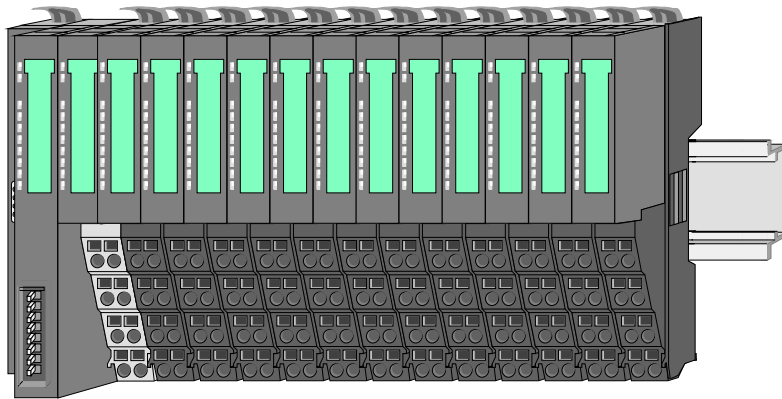

### Components

The FS200 consists of the following components:

- Bus coupler
- Periphery modules
- Power modules
- Accessories

### Bus coupler

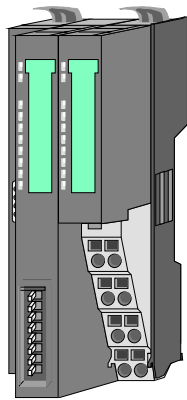

With a bus coupler bus interface and power module is integrated to one casing. With the bus interface you get access to a subordinated bus system.

Via the integrated power module for power supply the bus interface is supplied as well as the electronic of the connected periphery modules.

The DC 24 power section supply for the linked periphery modules is established via a further connection.

By installing of up to 64 periphery modules at the bus coupler, these are electrically connected, this means these are assigned to the backplane bus, the electronic modules are power supplied and each periphery module is connected to the DC 24V power section supply.

**Periphery modules** Each periphery module consists of a *terminal* and an *electronic* module.

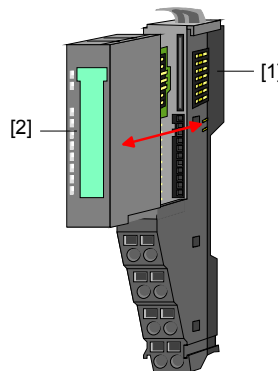
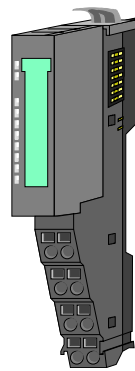

- [1] Terminal module
- [2] Electronic module

**Terminal module**

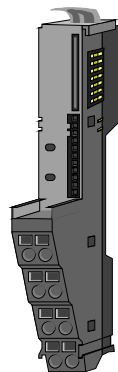

The *terminal module* serves to carry the electronic module, contains the backplane bus with power supply for the electronic, the DC 24V power section supply and the staircase-shaped terminal for wiring.

Additionally the terminal module has a locking system for fixing at a mounting rail.

By means of this locking system your FS200 may be assembled outside of your switchgear cabinet to be later mounted there as whole system.

**Electronic module**

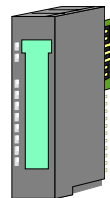

The functionality of a FS200 periphery module is defined by the *electronic module*, which is mounted to the terminal module by a slide mechanism.

With an error the defective module may be exchanged for a functional module with standing installation.

By an integrated coding only the modules may be plugged, which may be combined.

At the front side there are LEDs for status indication.

For simple wiring each module shows a corresponding connection diagram at the front and at the side.

**Power module**

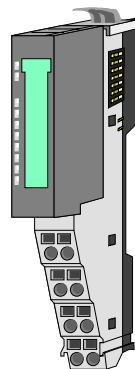

In the FS200 the power supply is established by power modules. These are either integrated to the bus coupler or may be installed between the periphery modules to define isolated areas of the DC 24V power section supply.

For better recognition the color of the power modules are contrasting to the periphery modules.

## Accessories

Shield bus carrier



The shield bus carrier serves to carry the shield bus to connect cable shields.

Shield bus carriers, shield bus and shield fixings are not in the scope of delivery. They are only available as accessories.

The shield bus carrier is mounted underneath the terminal of the terminal module.

With a flat mounting rail for adaption to a flat mounting rail you may remove the spacer of the shield bus carrier.

Bus cover

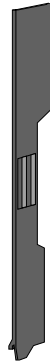

With each bus coupler, to protect the backplane bus connectors, there is a mounted bus cover in the scope of delivery.

You have to remove the bus cover of the bus coupler before mounting a FS200 module.

For the protection of the backplane bus connector you should always mount the bus cover at the last module of your system again.

## Dimensions

### Dimensions bus coupler



### Dimensions periphery module

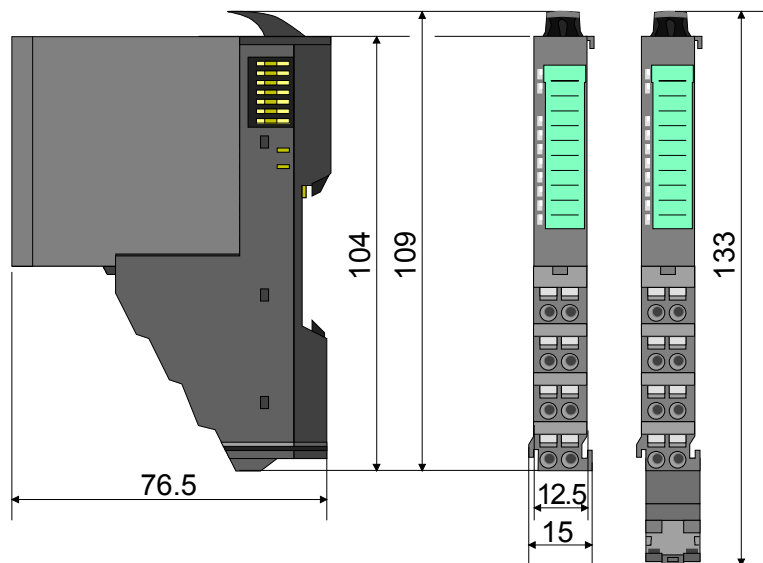

### Dimensions electronic module

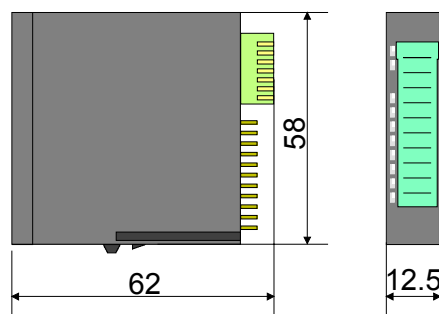

Dimensions in mm

# Installation

## Functional principle

### Mounting terminal module

There is a locking lever at the top side of the terminal module. For mounting and de-mounting this locking lever is to turn upwards until this engages audible.

Now the module may be pulled forward.

For mounting plug the module to the module installed before and push the module to the mounting rail guided by the strips at the upper and lower side of the module.

The module is fixed to the mounting rail by pushing downwards the locking lever.

The modules may either separately be mounted to the mounting rail or as block. Here is to be considered that each locking lever is opened.

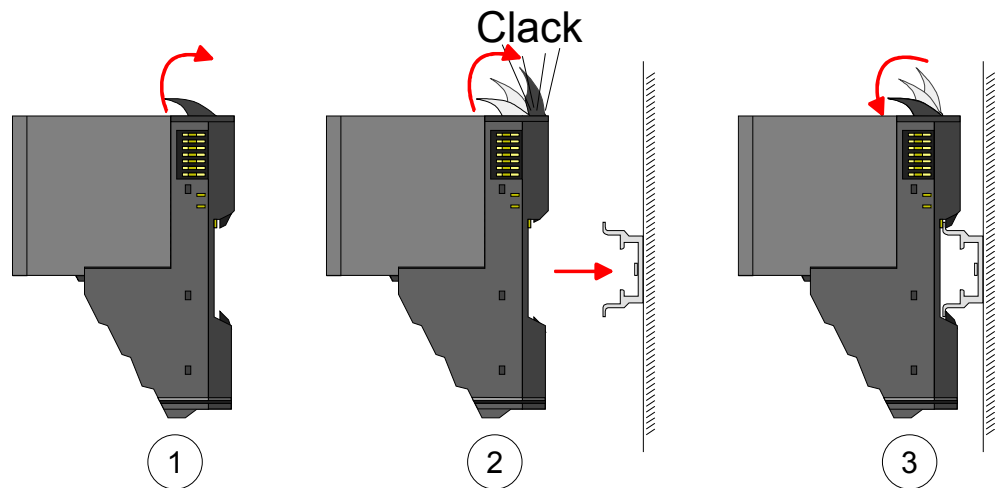

### Mounting electronic module

For mounting between 2 modules and for the exchange of a defective electronic module, the electronic module may be pulled forward after pressing the unlocking lever at the lower side of the module.

For installation plug the electronic module guided by the strips at the lower side until this engages audible to the terminal module.

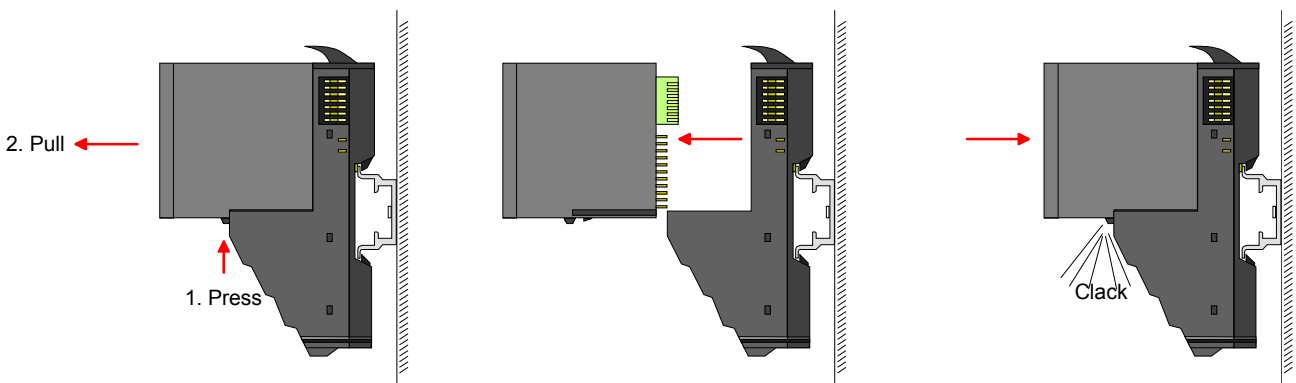

**Mounting Proceeding**

The modules were directly be mounted to the mounting rail and so connected to the backplane bus and the power supply for the electronic and power section.

Up to 64 modules may be mounted. Please consider here that the sum current of the electronic power supply does not exceed the maximum value of 3A.

**Mounting mounting rail**

- Mount the mounting rail! Please consider that a clearance from the middle of the mounting rail of at least 80mm above and 60mm below, respectively 80mm by deployment of shield bus carriers, exist.

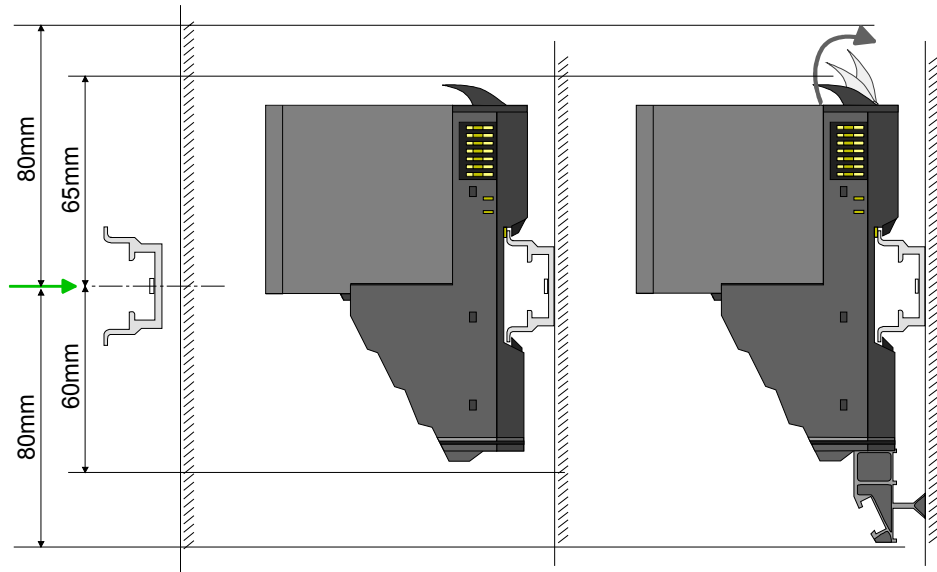

**Mounting Head module (e.g. bus coupler)**

- Start at the left side with the head module (e.g. bus coupler). For this turn both locking lever upwards, put the head module to the mounting rail and turn both locking lever downwards.
- Before mounting the periphery modules you have to remove the bus cover at the right side of the Head module by pulling it forward. Keep the cover for later mounting.

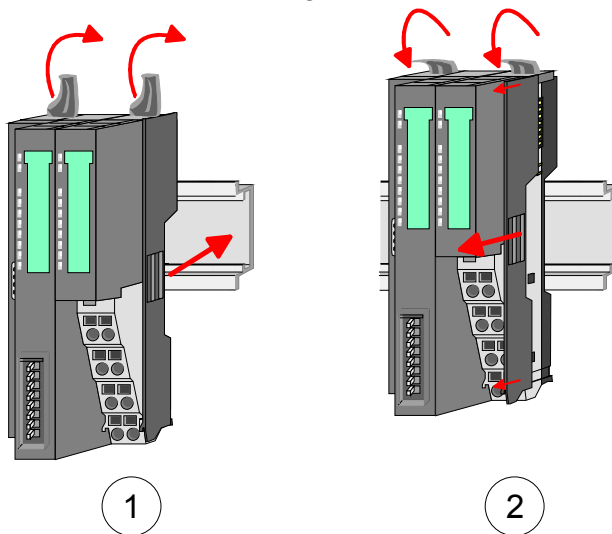

Mounting  
periphery module

- Mount the periphery modules you want.

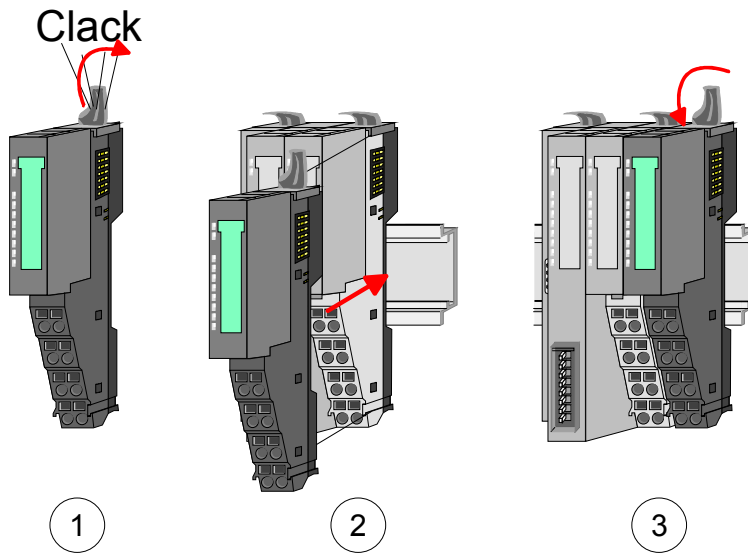

Mounting the  
bus cover

- After mounting the whole system, to protect the backplane bus connectors the bus cover may now be mounted at the last module

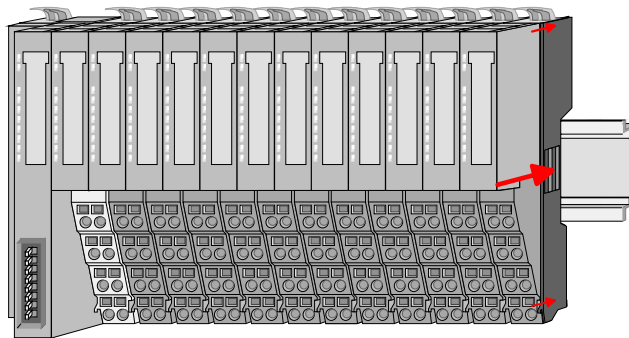

Mounting  
shield bus carrier

The shield bus carrier (available as accessory) serves to carry the shield bus to connect cable shields. The shield bus carrier is mounted underneath the terminal of the terminal module. With a flat mounting rail for adaption to a flat mounting rail you may remove the spacer of the shield bus carrier.

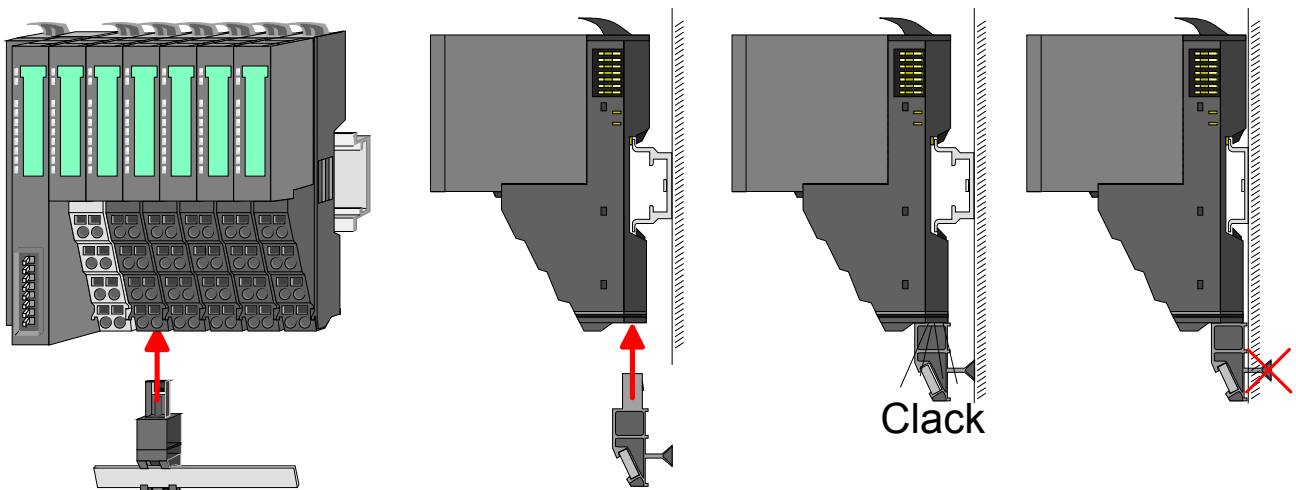



**Mounting between 2 modules**

With the mounting of a FS200 module respectively of a group of FS200 modules between two modules for mounting reasons you have always to remove the electronic module of the just mounted right module. After that it may be plugged again.

To mount the module put it to the gap between the both modules and push it, guided by the stripes at both sides, to the mounting rail.

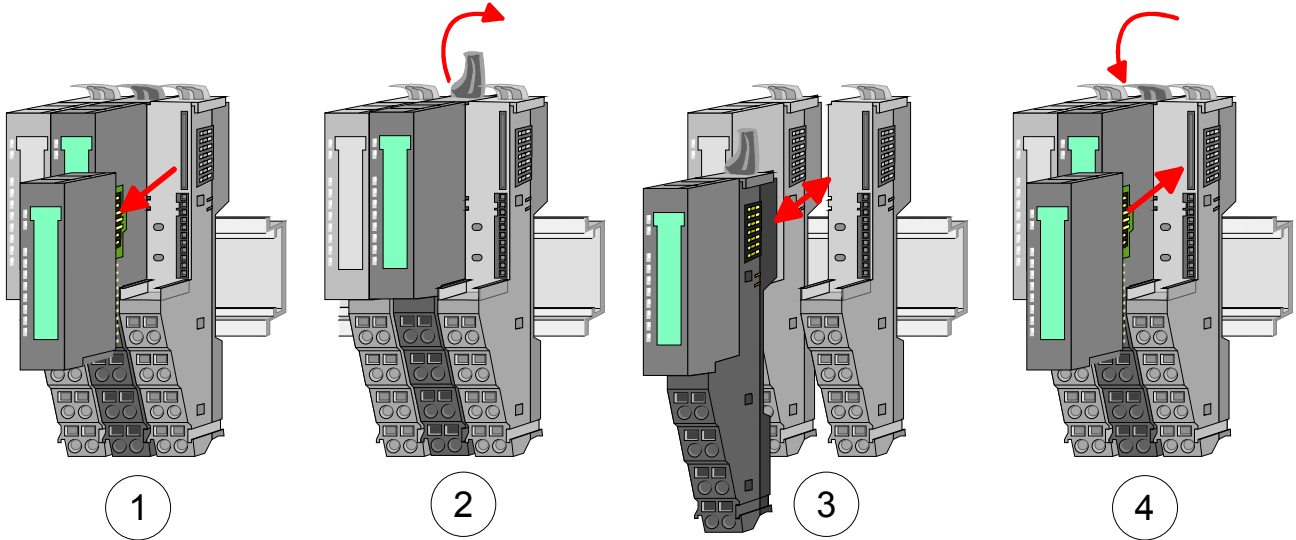

**1 module group between 2 modules**

With mounting respectively de-mounting of a module group you also have to remove the electronic module of the just mounted right module! After mounting it may be plugged again.

For mounting respectively de-mounting the locking lever of the modules of the block must be turned upwards.

To mount the group of modules put them to the gap between the both modules and push it, guided by the stripes at both sides, to the mounting rail.

After mounting the block turn each locking lever of the modules downwards.

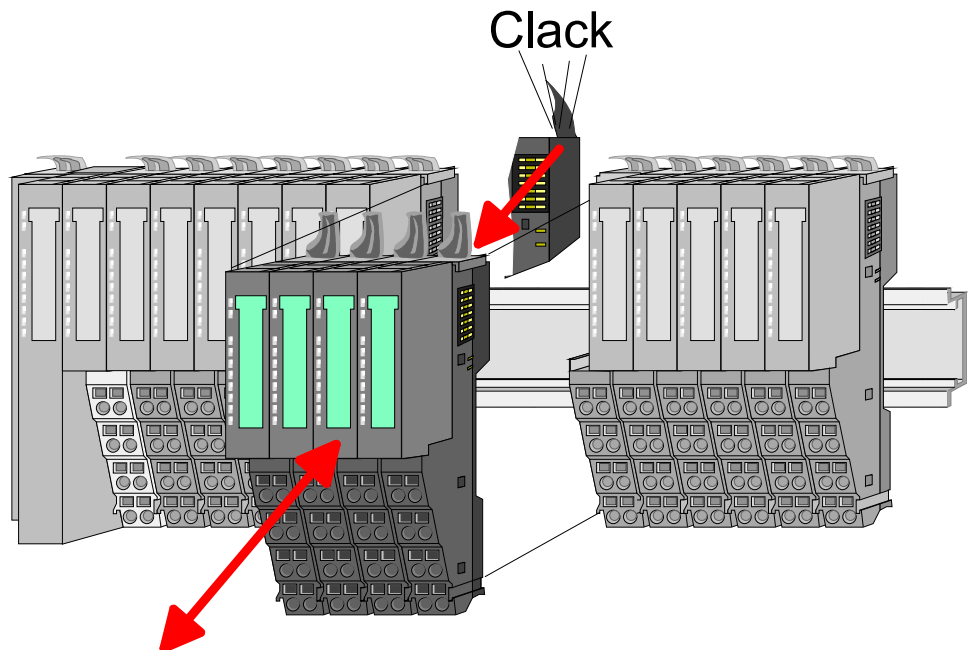

## Wiring

### Standard wiring

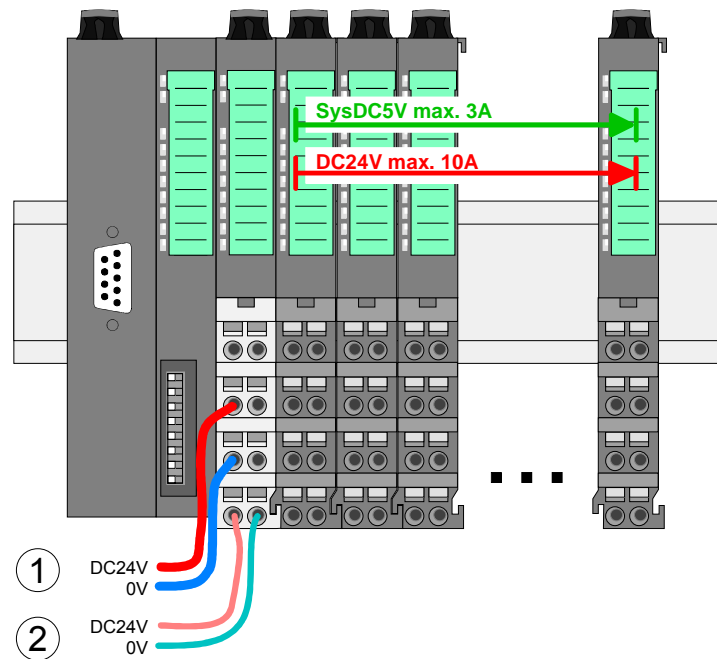

- [1] DC 24V Power section supply I/O area
- [2] DC 24V Electronic power supply bus coupler and I/O area



#### Note!

Power section and electronic power section supply are internally protected against higher voltage by fuses. The fuses are within the power module. If one fuse released, its electronic module must be exchanged!

It is recommended to protect the power section supply with a fast 10A fuse and the electronic power supply with a fast 4A fuse.

**Definition of isolated groups**

If the 10A for the power section supply is no longer sufficient, you may use the power module from ELCO with the order number FS2-PS-AB00.

So you have also the possibility to define isolated groups.

The following figure should illustrate the usage of the power modules.

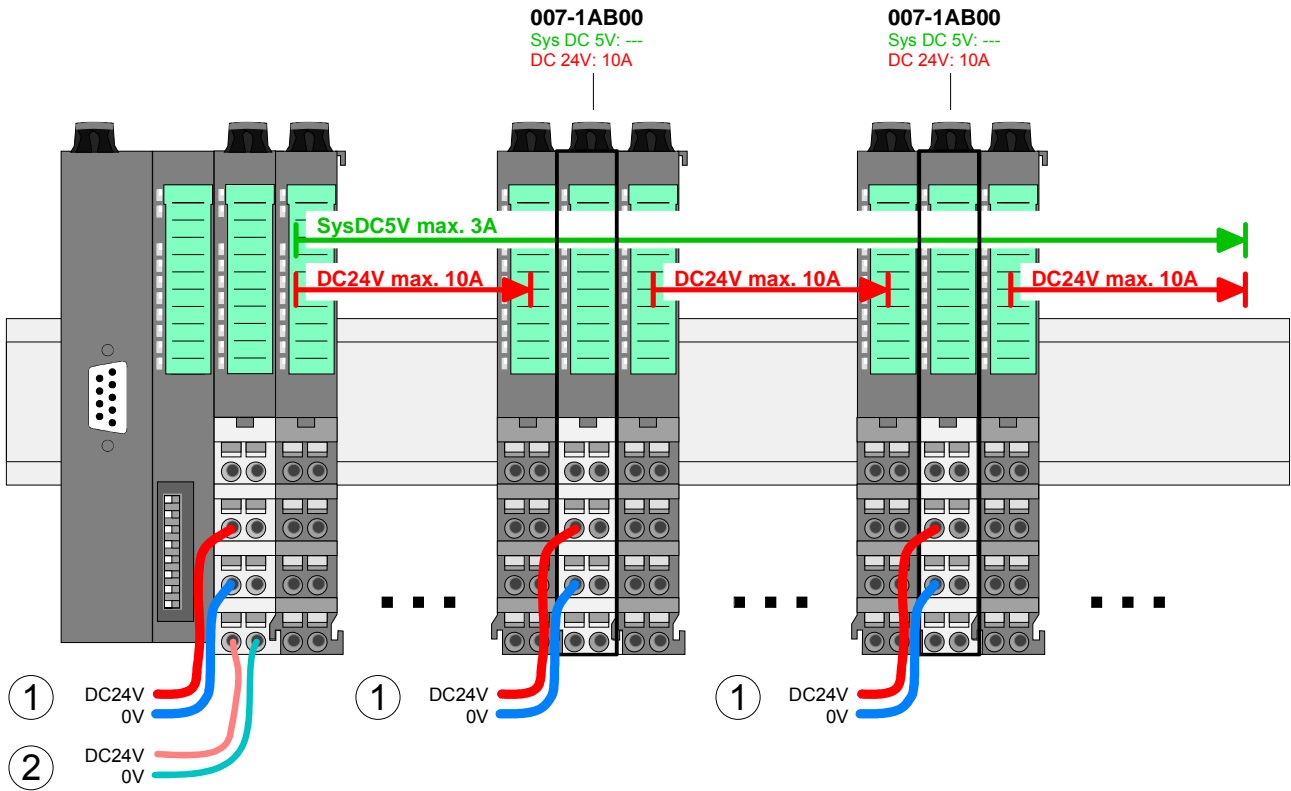

- [1] DC 24V Power section supply I/O area
- [2] DC 24V Electronic power supply bus coupler and I/O area

**Shield attachment**

To attach the shield the mounting of shield bus carriers are necessary.

The shield bus carrier (available as accessory) serves to carry the shield bus to connect cable shields.

The shield bus carrier is mounted underneath the terminal of the terminal module. With a flat mounting rail for adaption to a flat mounting rail you may remove the spacer of the shield bus carrier.

After mounting the shield bus carrier with the shield bus, the cables with the accordingly stripped cable screen may be attached and fixed by the shield clamp.

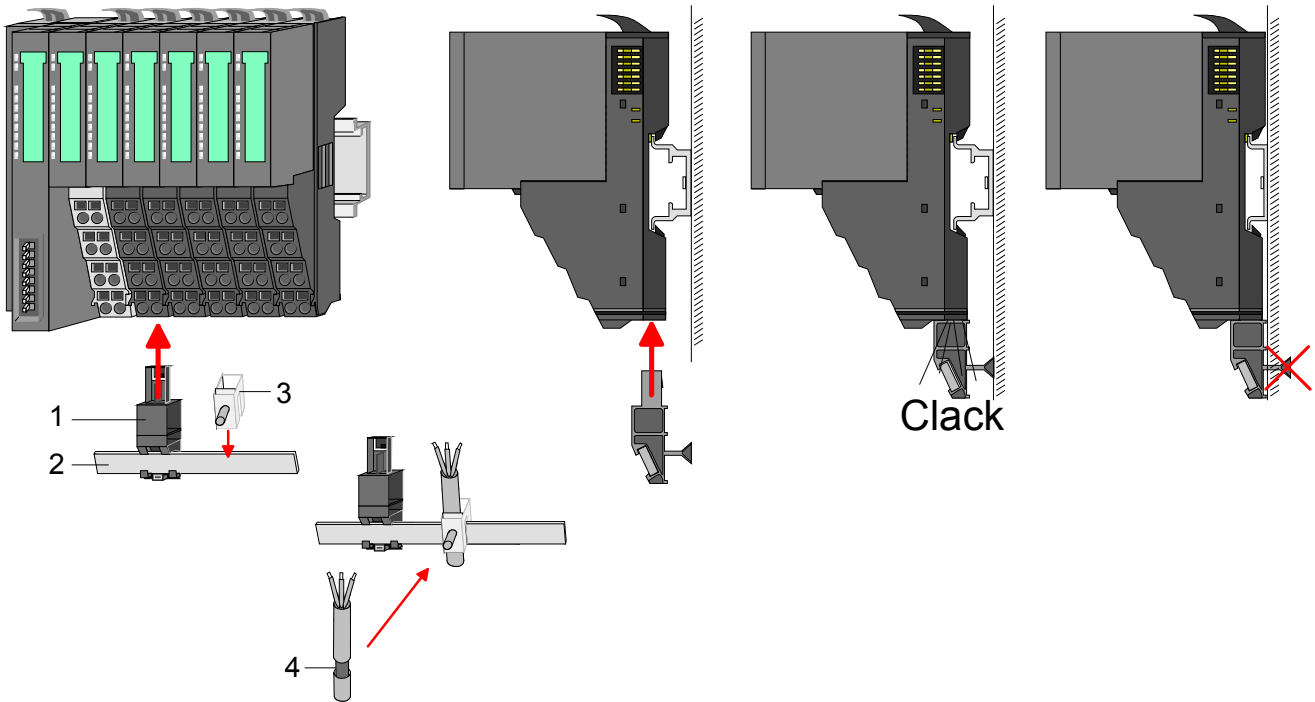

- [1] Shield bus carrier
- [2] Shield bus
- [3] Shield clamp
- [4] Cable shield

## Installation guidelines

**General** The installation guidelines contain information about the interference free deployment of FS200. There is the description of the ways, interference may occur in your control, how you can make sure the electromagnetic digestibility (EMC), and how you manage the isolation.

**What means EMC?** Electromagnetic digestibility (EMC) means the ability of an electrical device, to function error free in an electromagnetic environment without being interferenced res. without interfering the environment.  
All FS200 components are developed for the deployment in hard industrial environments and fulfill high demands on the EMC. Nevertheless you should project an EMC planning before installing the components and take conceivable interference causes into account.

**Possible interference causes** Electromagnetic interferences may interfere your control via different ways:

- Fields
- I/O signal conductors
- Bus system
- Current supply
- Protected earth conductor

Depending on the spreading medium (lead bound or lead free) and the distance to the interference cause, interferences to your control occur by means of different coupling mechanisms.

One differs:

- galvanic coupling
- capacitive coupling
- inductive coupling
- radiant coupling

**Basic rules for EMC**

In the most times it is enough to take care of some elementary rules to guarantee the EMC. Please regard the following basic rules when installing your PLC.

- Take care of a correct area-wide grounding of the inactive metal parts when installing your components.
  - Install a central connection between the ground and the protected earth conductor system.
  - Connect all inactive metal extensive and impedance-low.
  - Please try not to use aluminum parts. Aluminum is easily oxidizing and is therefore less suitable for grounding.
- When cabling, take care of the correct line routing.
  - Organize your cabling in line groups (high voltage, current supply, signal and data lines).
  - Always lay your high voltage lines and signal res. data lines in separate channels or bundles.
  - Route the signal and data lines as near as possible beside ground areas (e.g. suspension bars, metal rails, tin cabinet).
- Proof the correct fixing of the lead isolation.
  - Data lines must be laid isolated.
  - Analog lines must be laid isolated. When transmitting signals with small amplitudes the one sided laying of the isolation may be favorable.
  - Lay the line isolation extensively on an isolation/protected earth conductor rail directly after the cabinet entry and fix the isolation with cable clamps.
  - Make sure that the isolation/protected earth conductor rail is connected impedance-low with the cabinet.
  - Use metallic or metalized plug cases for isolated data lines.
- In special use cases you should appoint special EMC actions.
  - Wire all inductivities with erase links, which are not addressed by the FS200 modules.
  - For lightening cabinets you should prefer incandescent lamps and avoid luminescent lamps.
- Create a homogeneous reference potential and ground all electrical operating supplies when possible.
  - Please take care for the targeted employment of the grounding actions. The grounding of the PLC is a protection and functionality activity.
  - Connect installation parts and cabinets with the FS200 in star topology with the isolation/protected earth conductor system. So you avoid ground loops.
  - If potential differences between installation parts and cabinets occur, lay sufficiently dimensioned potential compensation lines.

**Isolation of conductors**

Electrical, magnetically and electromagnetic interference fields are weakened by means of an isolation, one talks of absorption.

Via the isolation rail, that is connected conductive with the rack, interference currents are shunt via cable isolation to the ground. Hereby you have to make sure, that the connection to the protected earth conductor is impedance-low, because otherwise the interference currents may appear as interference cause.

When isolating cables you have to regard the following:

- If possible, use only cables with isolation tangle.
- The hiding power of the isolation should be higher than 80%.
- Normally you should always lay the isolation of cables on both sides. Only by means of the both-sided connection of the isolation you achieve high quality interference suppression in the higher frequency area.  
Only as exception you may also lay the isolation one-sided. Then you only achieve the absorption of the lower frequencies. A one-sided isolation connection may be convenient, if:
  - the conduction of a potential compensating line is not possible
  - analog signals (some mV res.  $\mu\text{A}$ ) are transferred
  - foil isolations (static isolations) are used.
- With data lines always use metallic or metalized plugs for serial couplings. Fix the isolation of the data line at the plug rack. Do not lay the isolation on the PIN 1 of the plug bar!
- At stationary operation it is convenient to strip the insulated cable interruption free and lay it on the isolation/protected earth conductor line.
- To fix the isolation tangles use cable clamps out of metal. The clamps must clasp the isolation extensively and have well contact.
- Lay the isolation on an isolation rail directly after the entry of the cable in the cabinet. Lead the isolation further on to the FS200 module and **don't** lay it on there again!

**Please regard at installation!**

At potential differences between the grounding points, there may be a compensation current via the isolation connected at both sides.

Remedy: Potential compensation line

## General data

Conformity and approval		
Conformity		
CE	73/23/EWG	Low-voltage directive
Approval		
UL	UL 508	Approval for USA and Canada
others		
RoHs	-	Product is unleaded

Protection of persons and device protection		
Type of protection	-	IP20
Electrical isolation		
to the field bus	-	electrically isolated
to the process level	-	electrically isolated
Insulation resistance	EN 61131-2	-
Insulation voltage to reference earth		
Inputs / outputs	-	AC / DC 50V, test voltage AC 500V
Protective measures	-	against short circuit

Environmental conditions to EN 61131-2		
Climatic		
Storage / transport	EN 60068-2-14	-25...+70°C
Operation		
Horizontal installation	EN 61131-2	0...+60°C
Vertical installation	EN 61131-2	0...+55°C
Air humidity	EN 60068-2-30	RH1 (without condensation, rel. humidity 10...95%)
Pollution	EN 61131-2	Degree of pollution 2
<b>Mechanical</b>		
Oscillation	EN 60068-2-6	1G
Shock	EN 60068-2-27	15G

Mounting conditions		
Mounting place	-	In the control cabinet
Mounting position	-	Horizontal and vertical

EMC	Standard	Comment	
Emitted interference	EN 61000-6-4	Class A (Industry area)	
Noise immunity zone B	EN 61000-6-2	Industry area	
		EN 61000-4-2	ESD Degree of severity 3, i.e. 8kV at air discharge, 4kV at contact discharge
		EN 61000-4-3	HF irradiation (casing) 80MHz ... 1000MHz, 10V/m 80% AM (1kHz)
		EN 61000-4-6	HF conducted 150kHz ... 80MHz, 10V/m 80% AM (1kHz)
		EN 61000-4-4	Burst, degree of severity 3
	EN 61000-4-5	Surge, degree of severity 3	





## Chapter 2 Hardware description

**Overview** Here the hardware components of the FS2-GW-DP00 are more described. You will find the technical data at the end of this chapter.

<b>Content</b>	<b>Topic</b>	<b>Page</b>
	<b>Chapter 2 Hardware description .....</b>	<b>2-1</b>
	Properties.....	2-2
	Structure .....	2-3
	Technical data.....	2-6

## Properties

### Features

- Field bus: Profibus (DP-V0, DP-V1)
- Profibus DP slave for max. 64 periphery modules
- Max. 244byte input and 244byte output data
- Supports every Profibus transfer rates
- Integrated DC 24V power supply for power and electronic section supply of the periphery modules.

### Use as DP-V1 slave

- 1 MSAC\_C1 connection (Read, Write) with 244byte data (4byte DP-V1 header + 240byte user data)
- 3 MSAC\_C2 connections (Initiate, Read, Write, DataTransport, Abort) with each 244byte data (4byte DP-V1 header + 240byte user data)

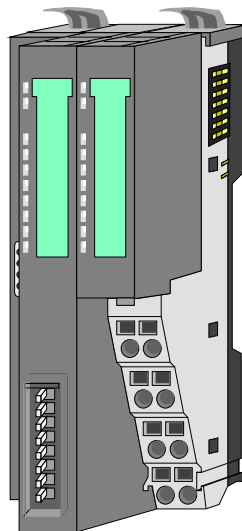

### Order data

Type	Order number	Description
FS2-GW	FS2-GW-DP00	Profibus DP slave for FS200

## Structure

### FS2-GW-DP00

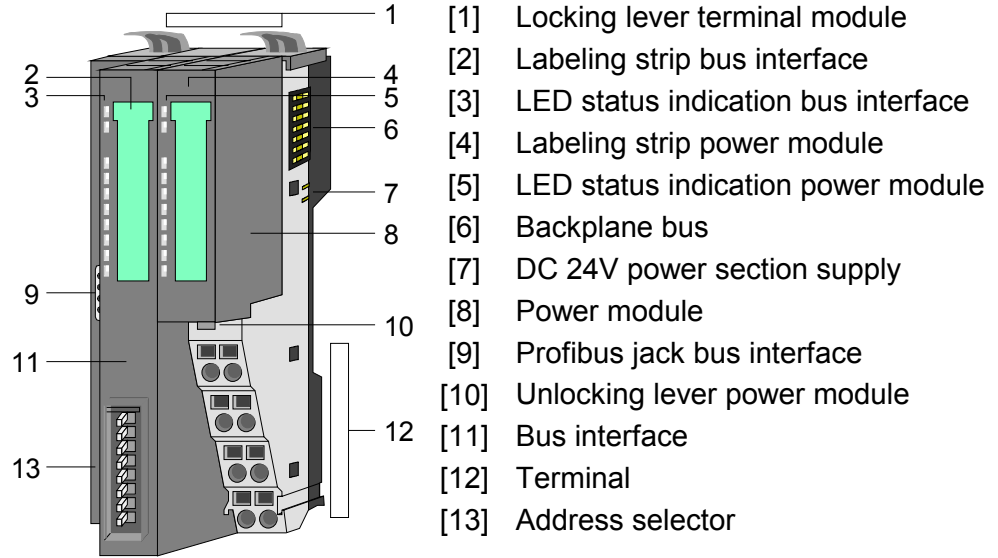

### Status indication bus coupler

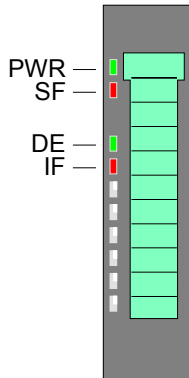

LED	Color	Description
PWR	green	● Bus coupler is power supplied
SF	red	● Station fault, structure is not corresponding to the configuration
DE	green	● State Data Exchange
		☼ Bus coupler is waiting for parameters
IF	red	● Internal error occurred

### Status indication power module

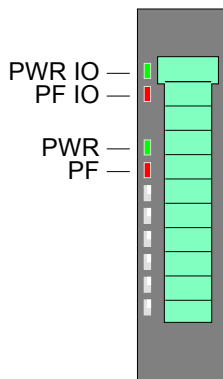

LED	Color	Description
PWR IO	green	● Power section supply OK
PF IO	red	● Fuse power section supply defective (Power fail)
		● Fuse electronic section supply defective
PWR	green	● Electronic section supply OK
PF	red	● Fuse electronic section supply defective

on: ● off: ○ blinking with 2Hz: ☼

**Terminal**

For wires with a core cross-section of 0.08mm<sup>2</sup> up to 2.5mm<sup>2</sup>.

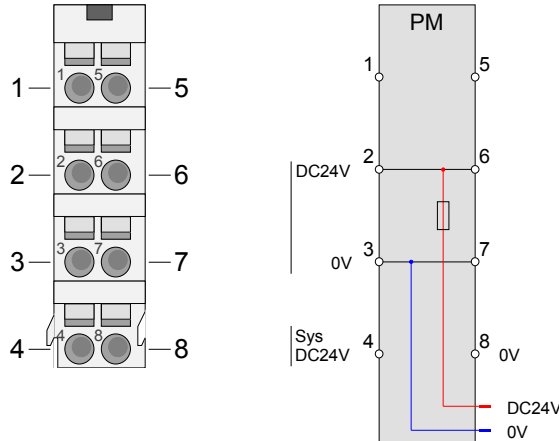

Pos.	Function	Type	Description
1	---	---	not connected
2	DC 24V	I	DC 24V for power section supply
3	0V	I	GND for power section supply
4	Sys DC 24V	I	DC 24V for electronic section supply
5	---	---	not connected
6	DC 24V	I	DC 24V for power section supply
7	0V	I	GND for power section supply
8	Sys 0V	I	GND for electronic section supply

I: Input

**Profibus jack bus coupler**

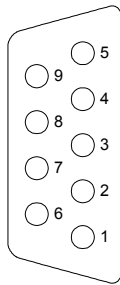

Pin	Assignment	Bus termination
1	Shield	
2	not connected	
3	RxD/TxD-P (line B)	
4	RTS	
5	M5V	
6	P5V	
7	not connected	
8	RxD/TxD-N (line A)	
9	not connected	

**Bus connection** The following picture illustrates the terminating resistors of the respective start and end station.

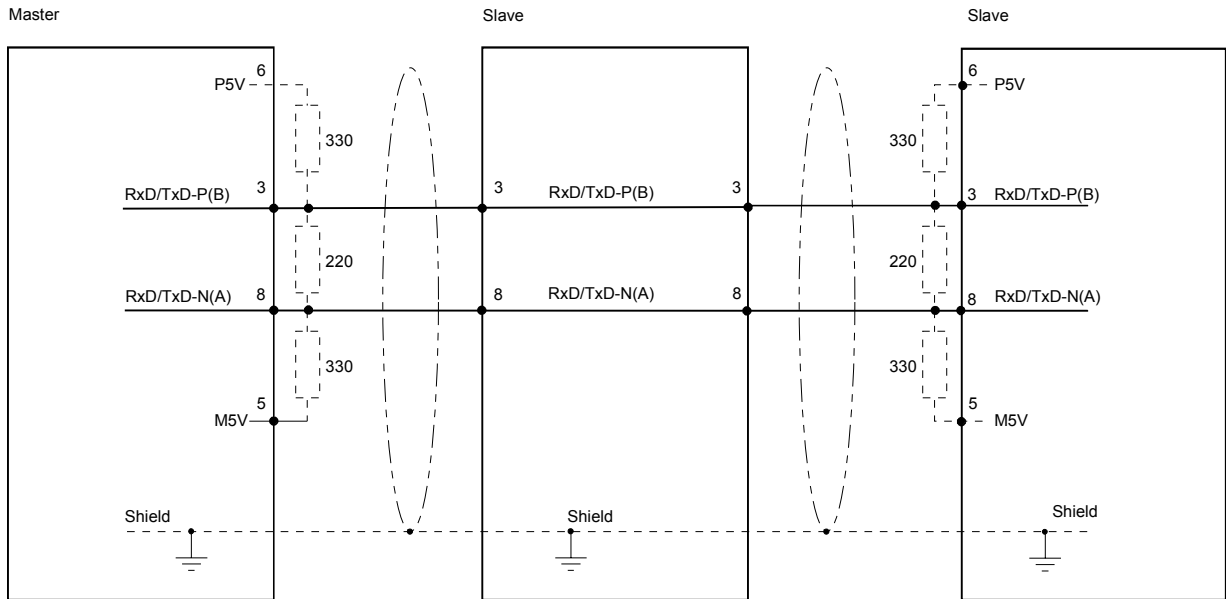

**Note!**

Please consider to terminate the last participants on the bus at both ends by activating the terminating resistor.

**Address selector**

Valid address may range from 1 to 125. Addresses must be unique on the bus.

The slave address must have been preset before the bus coupler is turned on.

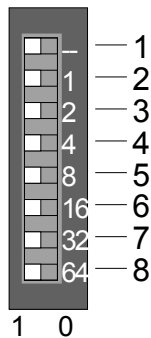

Pos.	Value	Example State	Address
1	not used	---	1+2+32=35 Address: 35
2	1	1	
3	2	1	
4	4	0	
5	8	0	
6	16	0	
7	32	1	
8	64	0	

## Technical data

Data	ELCO FS2-GW-DP00
Number of modules	64
Profiles	DP-V0 / DP-V1
Power supply	DC 24V (20.4 ... 28.8V)
Current consumption	
Electronic power supply	max. 1.9A
Power section supply	max. 10A
Current output	
Electronic power supply	max. 3A
Power section supply	max. 10A
Inputs	max. 244byte
Outputs	max. 244byte
Transfer rate	Automatic recognition up to 12Mbit/s
Coupling	9-pole SubD jack
Status display	LEDs at the front
Dimensions and weight	
Dimensions (WxHxD) in mm	48.5x109x76.5
Weight	155g

## Chapter 3 Deployment

**Overview** This chapter describes the usage of the FS2-GW-DP00 with Profibus. After a short introduction you may find here every information about assembly, project engineering and diagnostic. The chapter closes with the description of the firmware update.

<b>Content</b>	<b>Topic</b>	<b>Page</b>
	<b>Chapter 3 Deployment .....</b>	<b>3-1</b>
	Basics .....	3-2
	Project engineering .....	3-10
	DP-V1 services .....	3-13
	DP-V1 - I&M data .....	3-15
	Profibus installation guidelines .....	3-17
	Diagnostic functions .....	3-20
	Firmware update .....	3-28



## Basics

### General

Profibus is an international standard applicable to an open field bus for building, manufacturing and process automation. Profibus defines the technical and functional characteristics of a serial field bus system that can be used to create a low (sensor-/actuator level) or medium (process level) performance network of programmable logic controllers.

Together with other field bus systems, Profibus has been standardized in IEC 61158 since 1999. *IEC 61158* bears the title "Digital data communication for measurement and control - Field bus for use in industrial control systems".

Profibus comprises an assortment of compatible versions. The following details refer to Profibus DP.

### Profibus DP-V0

Profibus DP-V0 (*Decentralized Peripherals*) provides the basic functionality of DP, including cycle data exchange as well as diagnostics functions.

Profibus DP is a special protocol intended mainly for automation tasks in a manufacturing environment. DP is very fast, offers Plug'n'Play facilities and provides a cost-effective alternative to parallel cabling between PLC and remote I/O. Profibus DP was designed for high-speed cyclical data communication between bus master and slave systems.

### Profibus DP-V1

The original version, designed DP-V0, has been expanded to include version DP-V1, offering acyclic data exchange between master and slave.

*DP-V1* contains enhancements geared towards process automation, in particular acyclic data communication for parameter assignment, operation, visualization and alarm handling of intelligent field devices, parallel to cycle user data communication. This permits online access to station using engineering tools. In addition, DP-V1 defines alarms. Examples for different types of alarms are status alarm, update alarm and a manufacturer-specific alarm.

Please note in operating the DP V1 functionality that your DP master supports DP-V1 as well. For this you find details in the documentation to your DP master.

**Master and slaves** Profibus distinguishes between active stations (master) and passive stations (slave).

*Master devices*

Master devices control the data traffic at the bus. It is also possible to operate with multiple masters on a Profibus. This is referred to as multi-master operation. The protocol on the bus establishes a logical token ring between intelligent devices connected to the bus. Only the master that has the token, can communicate with its slaves.

A master is able to issue unsolicited messages if it is in possession of the access key (token). The Profibus protocol also refers to masters as active participants.

*Slave devices*

A Profibus slave acquires data from peripheral equipment, sensors, actuators and transducers. The ELCO Profibus couplers are modular slave devices that transfer data between the periphery and the high-level master.

In accordance with the Profibus standards these devices have no bus access rights. They are only allowed to acknowledge messages or return messages to a master when this has issued a request. Slaves are also referred to as passive participants.

**Master class 1  
MSAC\_C1**

The master of the class 1 is a central control that exchanges cyclically information with the decentral stations (slaves) in a defined message cycle. Typical MSAC\_C1 devices are controls (PLC) or PCs. MSAC\_C1 devices gain active bus access, which allows them to read the measuring values (inputs) of the field devices and to write the set points (outputs) of the actuators at a fixed time.

**Master class 2  
MSAC\_C2**

MSAC\_C2 are employed for service and diagnostic. Here connected devices may be configured, measuring values and parameters are evaluated and device states can be requested. MSAC\_C2 devices don't need to be connected to the bus system permanently. These also have active bus access.

Typical MSAC\_C2 devices are engineering, project engineering or operator devices.

**Communication** The bus transfer protocol provides two alternatives for the access to the bus:

**Master with master** Master communication is also referred to as token-passing procedure. The token-passing procedure guarantees the accessibility of the bus. The permission to access the bus is transferred between individual devices in the form of a "token". The token is a special message that is transferred via the bus.

When a master is in possession of the token it has the permission to access the bus and it can communicate with any active or passive device. The token retention time is defined when the system is configured. Once the token retention time has expired, the token is passed to the following master which now has permission to access the bus and may therefore communicate with any other device.

**Master-slave procedure** Data communication between a master and the slaves assigned to it is conducted automatically in a predefined and repetitive cycle by the master. You assign a slave to a specific master when you define the project. You can also define which DP slaves are included and which are excluded from the cyclic exchange of data.

Data communication between master and slave can be divided into a parameterization, a configuration and a data transfer phase. Before a DP slave is included in the data transfer phase the master checks whether the defined configuration corresponds with the actual configuration. This check is performed during the definition and configuration phase. The verification includes the device type, format and length information as well as the number of inputs and outputs. In this way a reliable protection from configuration errors is achieved.

The master handles the transfer of application related data independently and automatically. You can, however, also send new configuration settings to a bus coupler.

When the status of the master is DE "Data Exchange" it transmits a new series of output data to the slave and the reply from the slave contains the latest input data.

**Function cyclic data communication (DP-V0)**

DP-V0 provides the basic functionality of DP, including cycle data exchange as well as station diagnostic, module diagnostic and channel-specific diagnostic.

Data is transferred cyclically between the DP master and the DP slave by means of transmit and receive buffers.

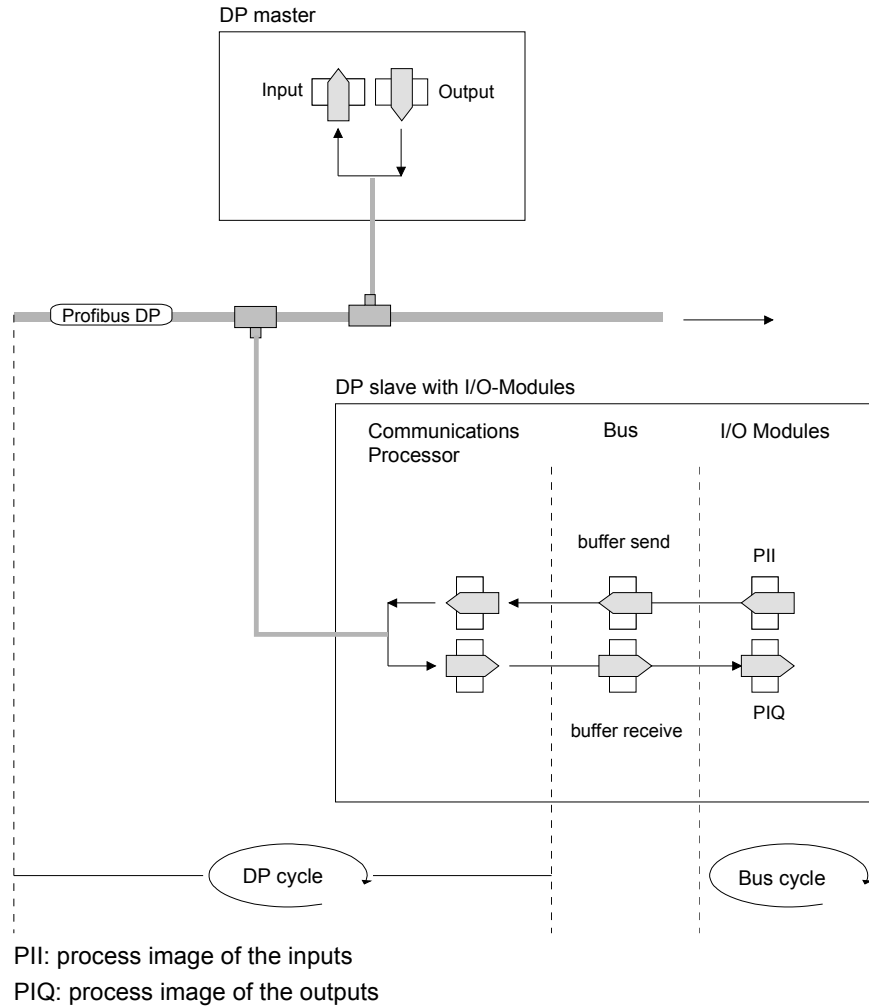

**Bus cycle**

A bus cycle saves all the input data from the modules in the PII and all the output data from the PIQ in the output modules. When the data has been saved the PII is transferred into the "buffer send" and the contents of the "buffer receive" is transferred into PIQ.

**DP cycle**

During a Profibus cycle the master addresses all its slaves according to the sequence defined in the data exchange. The data exchange reads and writes data from/into the memory areas assigned to the Profibus.

The contents of the Profibus input area is entered into the "buffer receive" and the data in the "buffer send" is transferred into the Profibus output area.

The exchange of data between DP master and DP slave is completed cyclically and it is independent from the bus cycle.

**Function  
acyclic data  
communication  
(DP-V1)**

The key feature of version DP-V1 is the extended function for acyclic data communication. This forms the requirement for parameterization and calibration of the field devices over the bus during runtime and for the introduction of confirmed alarm messages.

Transmission of acyclic data is executed parallel to cycle data communication, but with lower priority.

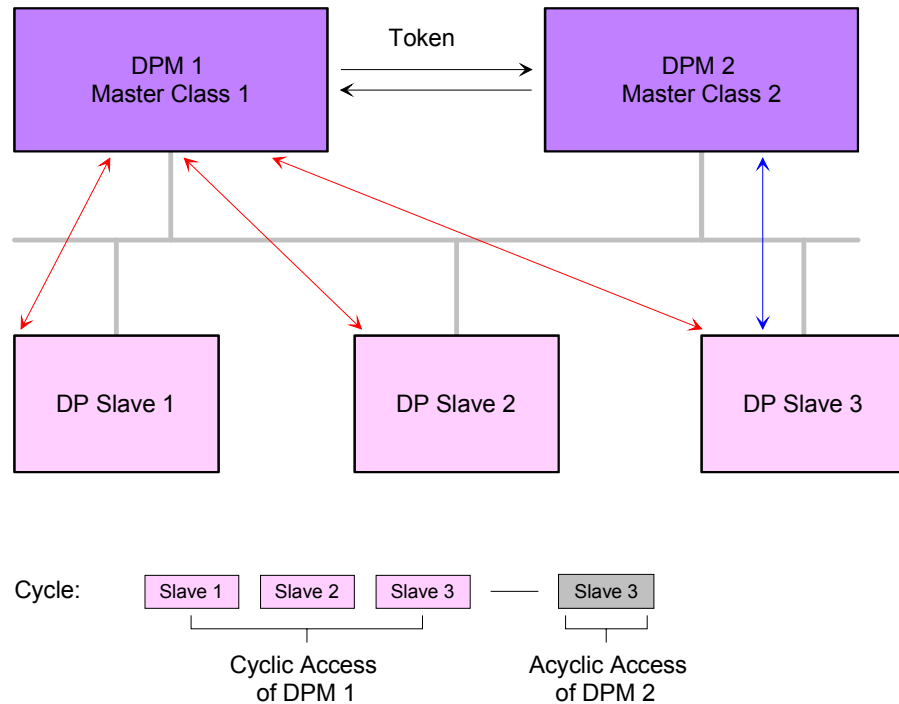

The DPM 1 (Master Class 1) has the token and is able to send messages to or retrieve them from slave 1, then slave 2, etc. in a fixed sequence until it reaches the last slave of the current list (MS0 channel); it then passes on the token to the DPM 2 (Master Class 2). This master can then use the remaining available time ("gap") of the programmed cycle to set up an acyclic connection to *any* slave (e.g. slave 3) to exchange records (MS2 channel); at the end of the current cycle time it returns the token to the DPM1.

The acyclic exchange of records can last for several scan cycles on their "gaps"; at the end, the DPM 2 uses the gap to clear the connection. Similarly as well as the DPM 2, the DPM 1 can also execute acyclic data exchange with slaves (MS1 channel).

**Addressing with Slot and Index**

When addressing data, Profibus assumes that the physical structure of the slaves is *modular* or it can be structured internally in logical functional units, so-called *modules*. This model is also used in the basic DP functions for cyclic data communication where each module has a constant number of input-/output bytes that are transmitted in a fixed position in the user data telegram. The addressing procedure is based on identifiers, which characterize a module type as input, output or a combination of both. All identifiers combined produce the configuration of the slave, which is also checked by the DPM when the system starts up.

The acyclic data communication is also based on this model. All data blocks enabled for read/write access are also regarded as assigned to the modules and can be addressed using slot number and index.

The *Slot\_Number* addresses the module and the *index* addresses the data blocks of a module. The Slot\_Number = 0 addresses data of the Profibus coupler, Slot\_Number > 0 addresses the data of the function modules.

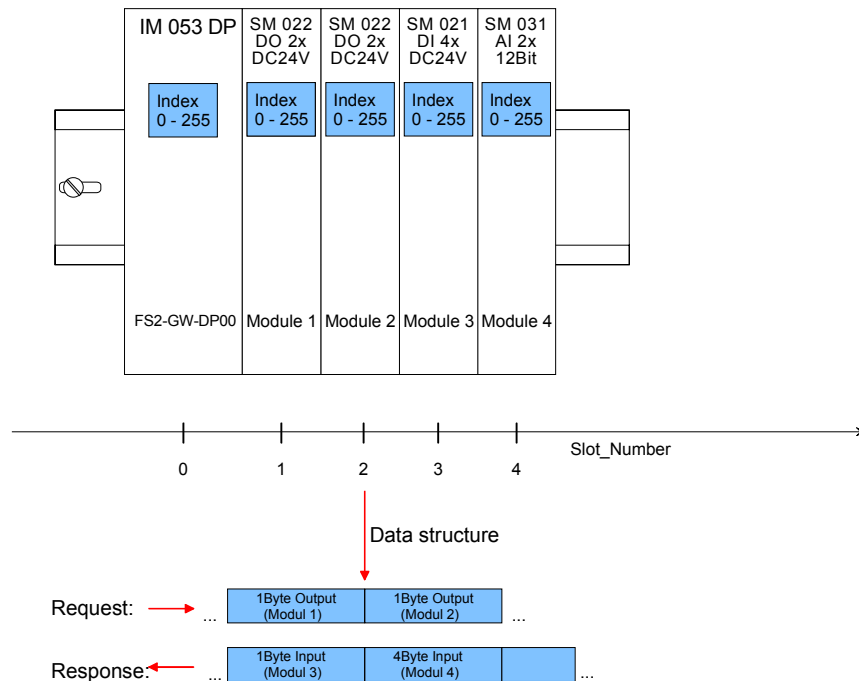

Each data block can be up to 244bytes. In the case of modular devices, the slot number is assigned to the modules. Compact devices are regarded as a unit of virtual modules. These can also be addressed with slot number and index. Through the length specification in the read/write request, it is also possible to read/write parts of a data block.



**Note!**

For the addressing at the deployment of the Siemens SIMATIC manager the following conventions are valid:

DP slave coupler: Setting of the *diagnostic address* as ID

Modules of the DP slave coupler: Setting of the *module address* as ID. For an output module you have to set additionally bit 15 of the module address (e.g. address 0004h becomes 8004h). With a combination module you have to set the lower one of the two addresses.

**Services  
acyclic data  
communication**

For the deployment of the DP-V1 services you have to take care that your master system supports DP-V1 communication. More detailed information about this may be found in the description of your master system. There are the following handling blocks available for CPUs, programmable with Siemens STEP7:

- SFB 52      Read record set from a DP slave
- SFB 53      Write record set to a DP slave
- SFB 54      Receive interrupt from a DP slave

In the following the services for the acyclic data transfer that are using that function blocks are shown.

More detailed information about the services and the DP-V0/V1 communication may be found in the Profibus norm IEC 61158.

DPM 1  
(Master class 1)

Acyclic data communication between DPM 1 and slaves	
Read	The master reads a data block from the slave.
Write	The master writes a data block to the slave.
Alarm	An alarm is transmitted from the slave to the master, which explicitly acknowledges receipt. The slave can only send a new alarm message after it has received this acknowledgment; this prevents any alarms being overwritten.
Alarm_Acknowledge	The master acknowledges receipt of an alarm to the slave.
Status	A status message is transmitted from the slave to the master. There is no acknowledgment.
Data transmission is connection-oriented over a MS1 connection. This is set up by the DPM 1 and is closely linked to the connection for cyclic data communication. It can be used by the master that has parameterized and configured the respective slave.	

DPM 2  
(Master class 2)

Services for acyclic data communication between DPM 2 and slaves	
Initiate / Abort	Setup and termination of a connection for acyclic data communication between DPM 2 and slave.
Read	The master reads a data block from the slave.
Write	The master writes a data block to the slave.
Data_Transport	The master can write application-specific data (specified in profiles) a cyclically to the slave and if required, read data from the slave in the same cycle.
Data transmission is connection-oriented over a MS2 connection. This is set up before the start of the acyclic data communication by the DPM 2 using the Initiate service. The connection is then available for Read, Write and Data_Transport services. The connection is terminated correspondingly. A slave can maintain several active MS2 connections simultaneously. A limitation is given by the resources available in the slave.	

---

### Data transfer medium as RS485 interface

Profibus employs screened twisted pair cable on the basis of the RS485 interface. The data transfer rate of the system is limited to a max. of 12Mbit/s.

The RS485 interface uses differential voltages. For this reason this kind of interface is less susceptible to interference than a plain voltage or current based interface. The network may be configured as linear or as tree structure. Your Profibus coupler carries a 9pin socket. This socket is used to connect the Profibus coupler to the Profibus network as a slave.

Due to the bus structure of RS485, any station may be connected or disconnected without interruptions and a system can be commissioned in different stages. Extensions to the system do not affect stations that have already been commissioned. Any failures of stations or new devices are detected automatically.

---

### Addressing

Every device on the Profibus is identified by an address. This address must be an unique number in the bus system for FS200 between 1 and 125.

---

### GSD- file

For every Profibus slave from ELCO there is a GSD file available. This file may either be found on the supplied storage media or at the download area of [www.elco-holding.com.cn](http://www.elco-holding.com.cn).

The assignment of the GSD-file to your slave is shown in the following table:

ELCO order number	GSD-file
ELCO FS2-GW-DP00(DP-V0)	FS200V0.gsd
ELCO FS2-GW-DP00(DP-V1)	FS200V1.gsd

Please install the required files into your configuration tool. Details on the installation of the GSD and/or type files are available from the manual supplied with your configuration tool.

After the installation of the GSD file you will find this entry e.g. the DP-V1 slave in the hardware catalog from Siemens at:

*Profibus DP > Additional field devices > I/O > ELCO FS200>  
ELCO FS2-GW-DP00(DP-V1)*



## Project engineering

### General

For project engineering a DP master engineering tool can be used like the Siemens SIMATIC manager. Here you assign the according Profibus DP slave modules to the DP master.

A direct assignment takes place via the Profibus address that you set at the DP slave address selector.

By installing the corresponding GSD file the FS2-GW-DP00 is listed at the hardware catalog as "ELCO FS2-GW-DP00 (DP-V0 or DP-V1)".

You'll find this at:

*Profibus DP >Additional Field devices>I/O> ELCO\_FS200*

### GSD- file

For every Profibus slave from ELCO there is a GSD file available. This file may either be found on the supplied storage media or at the download area of [www.elco-holding.com.cn](http://www.elco-holding.com.cn).

The assignment of the GSD-file to your slave is shown in the following table:

ELCO order number	GSD-file
ELCO FS2-GW-DP00(DP-V0)	FS200V0.gsd
ELCO FS2-GW-DP00(DP-V1)	FS200V1.gsd

Please install the required files into your configuration tool. Details on the installation of the GSD and/or type files are available from the manual supplied with your configuration tool.

After the installation of the GSD file you will find this entry e.g. the DP-V1 slave in the hardware catalog from Siemens at:

*Profibus DP >Additional field devices > I/O > ELCO\_FS200>  
ELCO FS2-GW-DP00(DPV1)*

### Project engineering

- Mount your Profibus system.
- Start your project engineering tool with a new project.
- Configure a master system and create a new Profibus subnet.
- For the project engineering of the FS2-GW-DP00 take the "ELCO FS2-GW-DP00 (DPV0)" or "ELCO FS2-GW-DP00 (DPV1)" for each functionality from the hardware catalog and drag it to the DP master subnet.
- Enter a Profibus address between 1 and 125 into the properties of the DP slave and set the same address at the address lever.
- Parameterize the DP slave (see parameters).
- Transfer your project to the PLC.

**Parameter data**  
**IM FS2-GW-DP00**  
**DP-V0**

At usage of the IM FS2-GW-DP00 (DP-V0) you have the following parameter data:

Byte	Bit 7 ... Bit 0	Default
0	Bit 2 ... 0: 0 (fix) Bit 3: 0 = WD-Timebase 10ms 1 = WD-Timebase 1ms Bit 4: 0 (fix) Bit 5: 0 = Publisher-Mode not available 1 = Publisher-Mode available	00h
1	00h (fix)	00h
2	08h (fix)	08h
3	0Ah (fix)	0Ah
4	81h (fix)	81h
5	00h (fix)	00h
6	00h (fix)	00h
7	Bit 0: 0 = Identifier-related diagnostic enable 1 = Identifier-related diagnostic disable Bit 1: 0 = Module status enable 1 = Module status disable Bit 2: 0 = Channel-related diagnostic enable 1 = Channel-related diagnostic disable Bit 3: 0 = Diagnostic enable 1 = Diagnostic disable Bit 4: 0 (fix) Bit 5: 0 = V0: Diagnostic interrupt not available 1 = V0: Diagnostic interrupt available Bit 6: 0 = V0: Hardware interrupt not available 1 = V0: Hardware interrupt available Bit 7: 0 (fix)	70h
8	Bit 6 ... 0: 0 (fix) Bit 7: 0 = Data format Motorola 1 = Data format Intel (only at analog modules)	00h
9 ... 12	00h (fix)	00h

**Parameter data  
IM FS2-GW-DP00  
DP-V1**

At usage of the IM FS2-GW-DP00 (DP-V1) you have the following parameter data:

Byte	Bit 7 ... Bit 0	Default
0	Bit 2 ... 0: 0 (fix) Bit 3: 0 = WD-Timebase 10ms 1 = WD-Timebase 1ms Bit 4: 0 (fix) Bit 5: 0 = Publisher-Mode not available 1 = Publisher-Mode available Bit 6: 0 = Fail-Safe-Mode not available 1 = Fail-Safe-Mode available Bit 7: 0 = DP-V1 mode disable 1 = DP-V1 mode enable	80h
1	Bit 0: Startup when expected/actual config. differ (must always be 0 else a parameterization error occurs) Bit 3 ... 1: 0 (fix) Bit 4: 0 = V1: Vendor-specific interrupt not available 1 = V1: Vendor-specific interrupt available Bit 5: 0 = V1: Diagnostic interrupt not available 1 = V1: Diagnostic interrupt available Bit 6: 0 = V1: Hardware interrupt not available 1 = V1: Hardware interrupt available Bit 7: 0 (fix)	70h
2	08h (fix)	08h
3	0Ah (fix)	0Ah
4	81h (fix)	81h
5	00h (fix)	00h
6	00h (fix)	00h
7	Bit 0: 0 = Identifier-related diagnostic enable 1 = Identifier-related diagnostic disable Bit 1: 0 = Module status enable 1 = Module status disable Bit 2: 0 = Channel-related diagnostic enable 1 = Channel-related diagnostic disable Bit 3: 0 = Diagnostic enable 1 = Diagnostic disable Bit 7 ... 4: 0 (fix)	00h
8	Bit 6 ... 0: 0 (fix) Bit 7: 0 = Data format Motorola 1 = Data format Intel (only at analog modules)	00h
9 ... 12	00h (fix)	00h

**Data format  
Motorola/Intel**

This parameter is exclusively evaluated with deployment of analog modules and refers to how a value is stored in the CPU address range.

In the *Motorola format* (default) the bytes were stored in descending significance, i.e. the 1. byte contains the high byte and 2. byte the low byte.

In the *Intel format* the value is switched and it is worked with ascending significance, i.e. the 1. byte contains the low byte and 2. byte the high byte.

## DP-V1 services

### Overview

For the deployment of the DP-V1 services you have to take care that your master system supports DP-V1 communication. More detailed information about this may be found in the description of your master system. There are the following handling blocks available for CPUs, programmable with Siemens STEP7:

- SFB 52      Read record set from a DP slave
- SFB 53      Write record set to a DP slave
- SFB 54      Receive interrupt from a DP slave

Per default, one class-1 master and max 3 class-2 master connection with 244byte data (4byte DP-V1 header plus 240byte user data) are supported.

The class-1 master connection is established together with the cyclic connection and is activated via the parameterization. The class-2 master connection can be used by a C2 master that then communicates with the slave only a cyclical and provides an own connection establishment.

### Data from DP-V1 slave

To access the DP-V1 slave with the Siemens SIMATIC manager the *diagnostic address*, which can be set by properties, is used as *ID*.

Using the following record set no. as *Index* you get access for reading (R) res. writing (W) to the listed DP slave elements:

Index	Access	Description
50h	R	Device name as ASCII code (ELCO FS2-GW-DP00)
51h	R	Hardware version as ASCII code (V1.00)
52h	R	Software version as ASCII code (V1.00)
53h	R	Serial number of the device in ASCII code (e.g. 00001347 = 30h, 30h, 30h, 30h, 31h, 33h, 34h, 37h)
54h	R	FPGA version unsigned16
58h	R	Device configuration (list of module types) 1. word: number n of modules 2. ... n. word: Module type
59h	R	FPGA version (list of FPGA versions) 1. word: FPGA version head module 2. ... n. word: FPGA version function modules
FFh	R	I&M functions
	W	I&M functions

### Device configuration

Via the index 58h, the module configuration of the DP slave may be monitored. With the 1. word you will get the number of modules. With the next words you will find the *module type* in the installed sequence.

The *module type* corresponds to the first 4 digits of the *module ID*. The *module ID* may be found in the technical data of the periphery module.

Data of the  
function modules

To access the function modules with the Siemens SIMATIC Manager the *module address*, which can be set by properties, is used as *ID*.

Using the following record set no. as *Index* you get access for reading (R) res. writing (W) to the listed function module elements:

Index	Access	Description
00h	R	Diagnostic - record set 0
	W	Parameter record set 0
01h	R	Diagnostic - record set 1
	W	Parameter record set 1
04h	R	read module process image
50h	R	Device name as ASCII code (ELCO FS2-AO-BB40)
51h	R	Hardware version as ASCII code (V1.00)
52h	R	Software version as ASCII code (V1.00)
53h	R	Serial number of the device in ASCII code (e.g. 00001347 = 30h, 30h, 30h, 30h, 31h, 33h, 34h, 37h)
54h	R	FPGA version unsigned16
7Dh	R/W	Every parameters record set 0 ... record set N
7Eh	R/W	Parameter record set 0
7Fh	R/W	Parameter record set 1
80h	R	Parameter record set 128
	W	Parameter record set 128
81h	R	Parameter record set 129
	W	Parameter record set 129
...		
AFh	R	Parameter record set 175
	W	Parameter record set 175
FFh	R	I&M Functions (only IM0)
	W	I&M Functions

## DP-V1 - I&M data

### Overview

Identification and maintenance data (I&M) are stored information in a module which support you at:

- check of the system configuration
- discover of hardware changes
- remove errors in a system

Identification data (I data) are information of the module e.g. order number, serial number, which can be found printed at the module.

I data are manufacturer information and can only be read.

Maintenance data (M data) are information like location and date of installation. M data were produced and stored during project engineering

By means of I&M data the modules can online be identified.



### Note!

Only one DP master may access at one time the I&M data.

### Structure

The data structure of the I&M data corresponds to the specifications of Profibus guideline - order no. 3.502, version 1.1 from May 2003.

I&M data	Access	Preset	Explanation
Identification data 0: IM_INDEX: 65000			
MANUFACTURER_ID	read (2byte)	022Bh (555)	Name of the manufacturer (555 = ELCO GmbH)
ORDER_ID	read (20byte)	depends on the module	Order number of the module ELCO FS2-GW-DP00
SERIAL_NUMBER	read (16byte)	depends on the module	Serial number of the module for clear identification.
HARDWARE_REVISION	read (2byte)	depends on the module	Hardware revision of the module which is incremented on changes at the firmware.

*continued ...*

... continue

I&M data	Access	Preset	Explanation
SOFTWARE_REVISION	read (4byte)	Firmware version Vxyz	Firmware version of the module. An increase of the firmware version also increases the hardware revision
REVISION_COUNTER	read (2byte)	0000h	reserved
PROFILE_ID	read (2byte)	F600h	Generic Device
PROFILE_SPECIFIC_TYPE	read (2byte)	0003h	at I/O modules
IM_VERSION	read (2byte)	0101h	Information about the version of the I&M data. (0101h = version 1.1)
IM_SUPPORTED	read (2byte)	001Fh	Information about available I&M- Data (IM_INDEX: 650000 ...65004)
Maintenance data 1: IM_INDEX: 65001			
TAG_FUNCTION	read/write (32byte)	–	Clear module ID inside the system
TAG_LOCATION	read/write (22byte)	–	Location of installation of the module
Maintenance data 2: IM_INDEX: 65002			
INSTALLATION_DATE	read/write (16byte)	–	Date and if applicable time of installation of the module
RESERVED	read/write (38byte)	–	reserved
Maintenance data 3: IM_INDEX: 65003			
DESCRIPTOR	read/write (54byte)	–	Commentary to the module
Maintenance data 4: IM_INDEX: 65004			
SIGNATURE	read/write (54byte)	–	Commentary to the module

## Profibus installation guidelines

### Profibus in general

- A Profibus DP network may only be built up in linear structure.
- Profibus DP consists of minimum one segment with at least one master and one slave.
- A master has always been deployed together with a CPU.
- Profibus supports max. 126 participants.
- Per segment a max. of 32 participants is permitted.
- The max. segment length depends on the transfer rate:
 

9.6 ... 187.5kbit/s	→	1000m
500kbit/s	→	400m
1.5Mbit/s	→	200m
3 ... 12Mbit/s	→	100m
- Max. 10 segments may be built up. The segments are connected via repeaters. Every repeater counts for one participant.
- All participants are communicating with the same transfer rate. The slaves adjust themselves automatically on the transfer rate.
- The bus has to be terminated at both ends.
- Master and slaves are free combinable.

### Transfer medium

As transfer medium Profibus uses an isolated twisted-pair cable based upon the RS485 interface.

The RS485 interface is working with voltage differences. Though it is less irritable from influences than a voltage or a current interface. You are able to configure the network as well linear as in a tree structure.

Via the Profibus jack the Profibus coupler is connected to the Profibus network.

Max. 32 participants per segment are permitted. The segments are connected via repeaters. The maximum segment length depends on the transfer rate.

Profibus DP uses a transfer rate between 9.6kbit/s and 12Mbit/s, the slaves are following automatically. All participants are communicating with the same transfer rate.

The bus structure under RS485 allows an easy connection res. disconnection of stations as well as starting the system step by step. Later expansions don't have any influence on stations that are already integrated. The system realizes automatically if one partner had a fail down or is new in the network.



**Bus connection**

The following picture illustrates the terminating resistors of the respective start and end station.

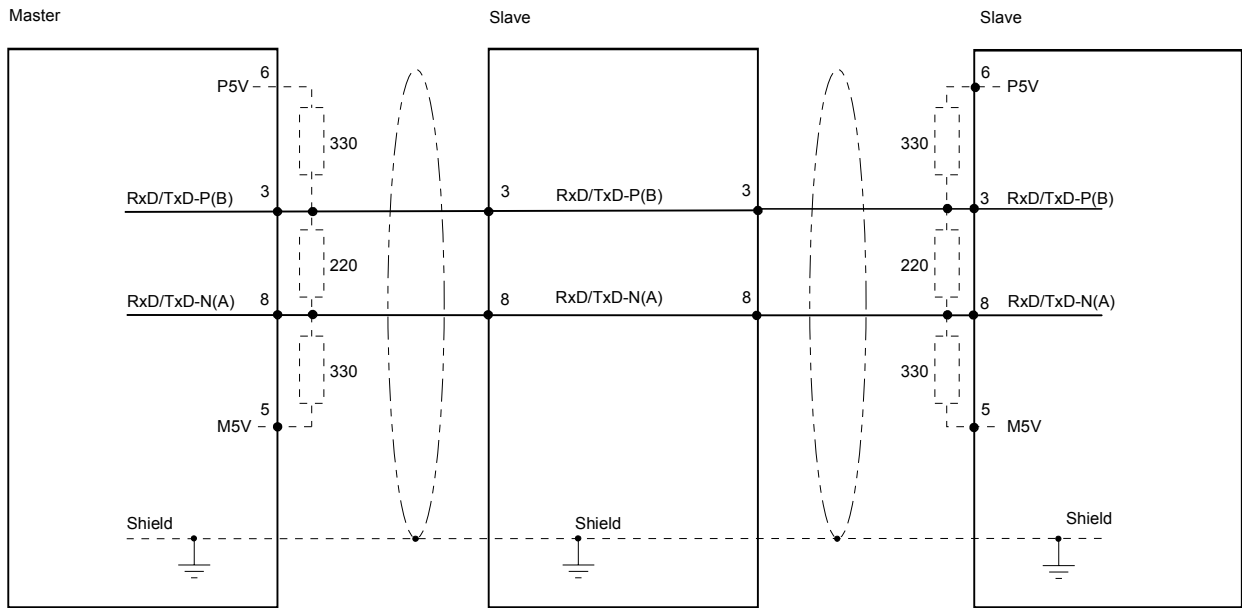

**Note!**

The Profibus line has to be terminated with its ripple resistor. Please make sure to terminate the last participants on the bus at both ends by activating the terminating resistor.

**EasyConn bus connector**



In systems with more than two stations all partners are wired in parallel. For that purpose, the bus cable must be feed-through uninterrupted.

Via the order number **ELCO FS2-972-DP10** you may order the bus connector "EasyConn". This is a bus connector with switchable terminating resistor and integrated bus diagnostic.

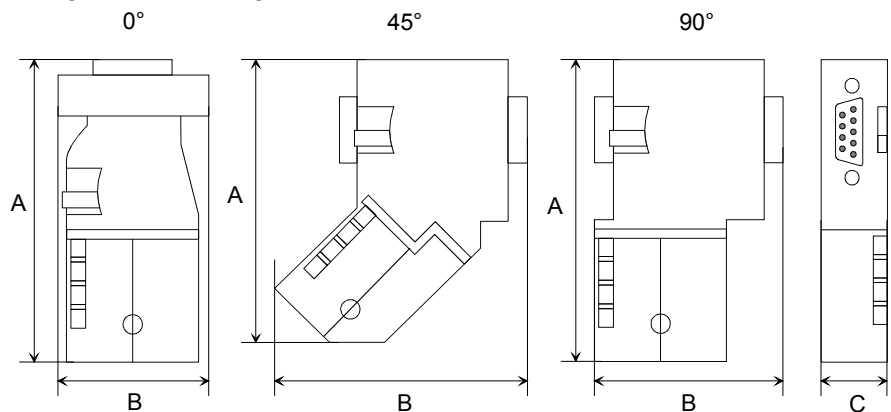

	0°	45°	90°
A	64	61	66
B	34	53	40
C	15.8	15.8	15.8

all in mm



**Note!**

To connect this EasyConn plug, please use the standard Profibus cable type A (EN50170). Starting with release 5 you also can use highly flexible bus cable: Lapp Kabel order no.: 2170222, 2170822, 2170322. With the order no. 905-6AA00 ELCO offers the "EasyStrip" de-isolating tool that makes the connection of the EasyConn much easier.



Dimensions in mm

Termination with "EasyConn"

The "EasyConn" bus connector is provided with a switch that is used to activate a terminating resistor.

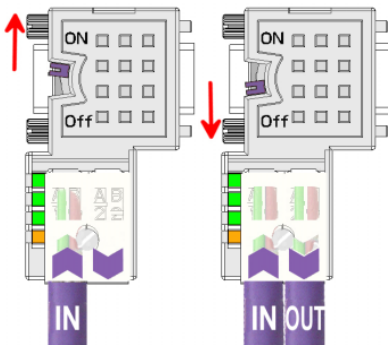

**Attention!**

The terminating resistor is only effective, if the connector is installed at a slave and the slave is connected to a power supply.

**Note!**

A complete description of installation and deployment of the terminating resistors is delivered with the connector.

Assembly

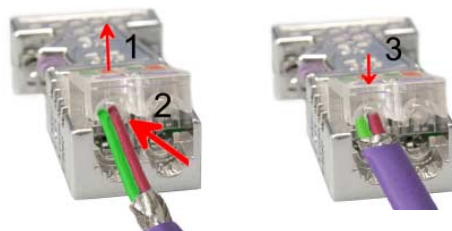

- Loosen the screw.
- Lift contact-cover.
- Insert both wires into the ducts provided (watch for the correct line color as below!)
- Please take care not to cause a short circuit between screen and data lines!
- Close the contact cover.
- Tighten screw (max. tightening torque 4Nm).

**Please note:**

The green line must be connected to A, the red line to B!

## Diagnostic functions

### Structure of the FS2-GW-DP00 diagnostic data

Profibus DP provides an extensive set of diagnostic functions for quick error localization. Diagnostic messages are transferred via the bus and collected by the master.

The diagnostic messages that are created by the Profibus slave have, depending on the parameterization, a length of 122byte.

As soon as the Profibus slave sends a diagnostic to the master, the max. of 122byte diagnostic data are prepended by 6byte standard diagnostic data:

Byte 0 ... 5	Standard diagnostic data: Is only prepended at transfer to the master via Profibus	May be enabled or disabled via parameterization
x ... x+8	Identifier-related diagnostic	
x ... x+19	Module status	
max. 21·(x ... x+2)	Channel-related diagnostic	
x ... x+19	Interrupt	

### Standard diagnostic data

At the transfer of a diagnostic to the master the slave standard diagnostic data are prepended to the diagnostic bytes. More detailed information to the structure of the slave standard diagnostic data is to find in the standard papers of the Profibus User Organization.

The slave standard diagnostic data have the following structure:

#### Standard diagnostic

Byte	Bit 7 ... Bit 0
0	Bit 0: Bit is always at 0 Bit 1: slave is not yet ready for exchange data Bit 2: Configuration data does not correspond to actual configuration Bit 3: External slave diagnostic available Bit 4: Request function is not supported by slave Bit 5: 0 (fix) Bit 6: Wrong parameterization Bit 7: 0 (fix)
1	Bit 0: New parameters have to be assigned to slave Bit 1: Statistic Diagnostic Bit 2: 1 (fix) Bit 3: Response monitoring has been enabled Bit 4: "FREEZE" control command received Bit 5: "SYNC" control command received Bit 6: reserved Bit 7: 0 (fix)
2	Bit 6 ... 0: reserved Bit 7: Diagnostic data overflow
3	Master address after parameterization FFh: Slave has not been parameterized
4	Ident number High Byte
5	Ident number Low Byte

**Identifier-related diagnostic**

Via the Identifier-related diagnostic you gain information at which plug-in location (module) an error has occurred.

More detailed information about the error is available via the *Module state* and the *channel-related diagnostic*.

The identifier-related diagnostic can be activated via the parameterization and has the following structure:

*Identifier-related diagnostic*

Byte	Bit 7 ... Bit 0
X	Bit 5 ... 0: 000101 (fix) Length of the Identifier-related diagnostic Bit 7 ... 6: 01 (fix) Code for Identifier-related diagnostic
X+1	The bit is set if one of the following occurs: - a module is removed - a not configured module is inserted - an inserted module cannot be accessed - a module reports a diagnostic interrupt Bit 0: Entry for module on slot 1 Bit 1: Entry for module on slot 2 Bit 2: Entry for module on slot 3 Bit 3: Entry for module on slot 4 Bit 4: Entry for module on slot 5 Bit 5: Entry for module on slot 6 Bit 6: Entry for module on slot 7 Bit 7: Entry for module on slot 8
X+2	Bit 0: Entry for module on slot 9 Bit 1: Entry for module on slot 10 Bit 2: Entry for module on slot 11 Bit 3: Entry for module on slot 12 Bit 4: Entry for module on slot 13 Bit 5: Entry for module on slot 14 Bit 6: Entry for module on slot 15 Bit 7: Entry for module on slot 16
X+3	Bit 0: Entry for module on slot 17 Bit 1: Entry for module on slot 18 Bit 2: Entry for module on slot 19 Bit 3: Entry for module on slot 20 Bit 4: Entry for module on slot 21 Bit 5: Entry for module on slot 22 Bit 6: Entry for module on slot 23 Bit 7: Entry for module on slot 24
X+4	Bit 0: Entry for module on slot 25 Bit 1: Entry for module on slot 26 Bit 2: Entry for module on slot 27 Bit 3: Entry for module on slot 28 Bit 4: Entry for module on slot 29 Bit 5: Entry for module on slot 30 Bit 6: Entry for module on slot 31 Bit 7: Entry for module on slot 32

*continued ...*

... continue

Byte	Bit 7 ... Bit 0
X+5	Bit 0: Entry for module on slot 33 Bit 1: Entry for module on slot 34 Bit 2: Entry for module on slot 35 Bit 3: Entry for module on slot 36 Bit 4: Entry for module on slot 37 Bit 5: Entry for module on slot 38 Bit 6: Entry for module on slot 39 Bit 7: Entry for module on slot 40
X+6	Bit 0: Entry for module on slot 41 Bit 1: Entry for module on slot 42 Bit 2: Entry for module on slot 43 Bit 3: Entry for module on slot 44 Bit 4: Entry for module on slot 45 Bit 5: Entry for module on slot 46 Bit 6: Entry for module on slot 47 Bit 7: Entry for module on slot 48
X+7	Bit 0: Entry for module on slot 49 Bit 1: Entry for module on slot 50 Bit 2: Entry for module on slot 51 Bit 3: Entry for module on slot 52 Bit 4: Entry for module on slot 53 Bit 5: Entry for module on slot 54 Bit 6: Entry for module on slot 55 Bit 7: Entry for module on slot 56
X+8	Bit 0: Entry for module on slot 57 Bit 1: Entry for module on slot 58 Bit 2: Entry for module on slot 59 Bit 3: Entry for module on slot 60 Bit 4: Entry for module on slot 61 Bit 5: Entry for module on slot 62 Bit 6: Entry for module on slot 63 Bit 7: Entry for module on slot 64

**Module status**

The module status gives you detailed information about the error that occurred at a module.

The module status can be activated via the parameterization and has the following structure:

*Module status*

Byte	Bit 7 ... Bit 0
X	Bit 5 ... 0: 001100 (fix) Length of the Module status Bit 7 ... 6: 00 (fix) Code for Module status
X+1	82h (fix) Status type Module status
X+2	00h (fix)
X+3	00h (fix)
X+4	Follow bits indicates the status of the modules from slot 1 ... 32 00: Module ok - valid data 01: Module error - invalid data (Module defective) 10: Incorrect module - invalid data 11: No module - invalid data Bit 1, 0: Module status module slot 1 Bit 3, 2: Module status module slot 2 Bit 5, 4: Module status module slot 3 Bit 7, 6: Module status module slot 4
X+5	Bit 1, 0: Module status module slot 5 Bit 3, 2: Module status module slot 6 Bit 5, 4: Module status module slot 7 Bit 7, 6: Module status module slot 8
X+6	Bit 1, 0: Module status module slot 9 Bit 3, 2: Module status module slot 10 Bit 5, 4: Module status module slot 11 Bit 7, 6: Module status module slot 12
X+7	Bit 1, 0: Module status module slot 13 Bit 3, 2: Module status module slot 14 Bit 5, 4: Module status module slot 15 Bit 7, 6: Module status module slot 16
X+8	Bit 1, 0: Module status module slot 17 Bit 3, 2: Module status module slot 18 Bit 5, 4: Module status module slot 19 Bit 7, 6: Module status module slot 20
X+9	Bit 1, 0: Module status module slot 21 Bit 3, 2: Module status module slot 22 Bit 5, 4: Module status module slot 23 Bit 7, 6: Module status module slot 24
X+10	Bit 1, 0: Module status module slot 25 Bit 3, 2: Module status module slot 26 Bit 5, 4: Module status module slot 27 Bit 7, 6: Module status module slot 28
X+11	Bit 1, 0: Module status module slot 29 Bit 3, 2: Module status module slot 30 Bit 5, 4: Module status module slot 31 Bit 7, 6: Module status module slot 32
X+12	Bit 1, 0: Module status module slot 33 Bit 3, 2: Module status module slot 34 Bit 5, 4: Module status module slot 35 Bit 7, 6: Module status module slot 36

*continued ...*

... continue

Byte	Bit 7 ... Bit 0
X+13	Bit 1, 0: Module status module slot 37 Bit 3, 2: Module status module slot 38 Bit 5, 4: Module status module slot 39 Bit 7, 6: Module status module slot 40
X+14	Bit 1, 0: Module status module slot 41 Bit 3, 2: Module status module slot 42 Bit 5, 4: Module status module slot 43 Bit 7, 6: Module status module slot 44
X+15	Bit 1, 0: Module status module slot 45 Bit 3, 2: Module status module slot 46 Bit 5, 4: Module status module slot 47 Bit 7, 6: Module status module slot 48
X+16	Bit 1, 0: Module status module slot 49 Bit 3, 2: Module status module slot 50 Bit 5, 4: Module status module slot 51 Bit 7, 6: Module status module slot 52
X+17	Bit 1, 0: Module status module slot 53 Bit 3, 2: Module status module slot 54 Bit 5, 4: Module status module slot 55 Bit 7, 6: Module status module slot 56
X+18	Bit 1, 0: Module status module slot 57 Bit 3, 2: Module status module slot 58 Bit 5, 4: Module status module slot 59 Bit 7, 6: Module status module slot 60
X+19	Bit 1, 0: Module status module slot 61 Bit 3, 2: Module status module slot 62 Bit 5, 4: Module status module slot 63 Bit 7, 6: Module status module slot 64

**Channel-related Diagnostic**

With the channel-related diagnostic you gain detailed information about the channel error within a module. For the usage of the channel-related diagnostic you have to release the diagnostic interrupt for every module via the parameterization. The channel-related diagnostic can be activated via the parameterization and has the following structure:

*Channel-related diagnostic*

Byte	Bit 7 ... Bit 0
X	Bit 5 ... 0: ID number of the module that delivers the channel-specific diagnostic (000001 ... 011111) e.g.: Slot 1 has ID no. 0 Slot 32 has ID no. 31 Bit 7, 6: 10 (fix) Code for channel-related diagnostic
X+1	Bit 5 ... 0: Number of the channel or the channel group that delivers the diagnostic (00000 ... 11111) Bit 7 ... 6: 01=Input Module 10=Output Module 11=In-/Output Module
X+2	Bit 4 ... 0: <i>Error messages to Profibus standard</i> 00001: Short circuit 00010: Undervoltage (Supply voltage) 00011: Overvoltage (Supply voltage) 00100: Output Module is overloaded 00101: Temperature rise output Module 00110: Open circuit sensors or actors 00111: Upper limit violation 01000: Lower limit violation 01001: Error - Load voltage at the output - Sensor supply - Hardware error in the Module  <i>Error messages - manufacturer-specific</i> 10000: Parameter assignment error 10001: Sensor or load voltage missing 10010: Fuse defect 10100: Ground fault 10101: Reference channel error 10110: Hardware interrupt lost 11001: Safety-related shutdown 11010: External fault 11010: Indefinable error - not specified  Bit 7 ... 5: Channel type 001: bit 010: 2bit 011: 4bit 100: byte 101: word 110: 2words

The maximum number of channel-related diagnostic is limited by the total length of 122byte for diagnostic. By de-activating of other diagnostic ranges you may release these areas for further channel-related diagnostic. For each channel always 3byte are used.



**Interrupts** The interrupt section of the slave diagnostic shows information about interrupt type and cause. It consists of max. 20byte. For every slave diagnostic max. 1 interrupt can be send. The interrupt section is always the last part of the diagnostic telegram if activated it in the parameterization.

**Structure** Depending on the interrupt type, the interrupt section has the following structure:

Byte	Element	Description
x...x+3	Interrupt status	Contains information about the interrupt type
x+4...x+19	Diagnostic interrupt	The 16byte correspond to the record set 1 of the CPU diagnostic
x+4...x+7	Hardware interrupt	The 4byte are module specific and are described with the according module.

**Interrupt status** If there is a diagnostic event for channel/group 0 of a module, there may be a module error as well as a channel error. The entry is made in this case even if you have not enabled the diagnostic for channel (/channel group) 0 of a module.

The interrupt section is structured as follows:

*Interrupt status byte x ... x+3*

Byte	Bit 7 ... Bit 0
x	Bit 5 ... 0: 010100: Length of the interrupt section incl. byte x Bit 7 ... 6: 00 (fix) Code for Module-related diagnostic
x+1	Bit 6 ... 0: Type of interrupt 0000001: Diagnostic interrupt 0000010: Hardware interrupt Bit 7: Code for interrupt
x+2	Bit 7 ... 0: Slot of the module that is producing interrupt 1 ... 32
x+3	Bit 1, 0: 00: Hardware interrupt 01: Diagnostic interrupt <sub>incoming</sub> 10: Diagnostic interrupt <sub>outgoing</sub> 11: reserved Bit 2: 0 (fix) Bit 7 ... 3: interrupt sequence number 1 ...32

*Interrupt status at diagnostic interrupt bytes x+4 to x+19*

Byte	Bit 7 ... Bit 0
x+4	Bit 0: Module malfunction, i.e. a problem has been detected Bit 1: Internal error in the module Bit 2: External error - module no longer addressable Bit 3: Channel error in the module Bit 4: Load power supply is missing Bit 5: Front connector is missing Bit 6: Module is not parameterized Bit 7: Parameter assignment error
x+5	Bit 3 ... 0: Module class 1111: Digital module 0101: Analog module 1000: FM 1100: CP Bit 4: Channel information available Bit 5: User information available Bit 6: 0 (fix) Bit 7: 0 (fix)
x+6	Bit 0: Memory or coding key analog module is missing Bit 1: Communication error Bit 2: Operating mode 0: RUN 1: STOP Bit 3: Cycle time monitoring addressed Bit 4: Module power supply failure Bit 5: Empty battery Bit 6: Complete backup failure Bit 7: 0 (fix)
x+7	Bit 5 ... 0: reserved Bit 6: Hardware interrupt lost Bit 7: reserved
x+8	70h: Module with digital inputs 71h: Module with analog inputs 72h: Module with digital outputs 73h: Module with analog outputs 74h: Module with analog in-/-outputs 76h: Counter
x+9	Length of the channel-related diagnostic
x+10	Number of channels per module
x+11	Position (channel) with diagnostic event
x+12	Diagnostic event on the channel/channel group 0 Assignment see module description
x+13	Diagnostic event on the channel/channel group 1 Assignment see module description
...	...
x+19	Diagnostic event on the channel/channel group 7 Assignment see module description

*Interrupt status at hardware interrupt bytes x+4 to x+7*

More detailed information to the diagnostic data may be found in the concerning module descriptions.

## Firmware update

### Overview

The firmware update for the DP-V1 slave ELCO FS2-GW-DP00 happens via Profibus and is only available with CPUs with DP-V1 capability like Siemens CPUs.

For this your firmware is online transferred from the hardware configurator to the CPU, which passes the firmware on to the according DP slave via the connected DP master using Profibus.

### Approach

- Make firmware file available
- Load project into the hardware configurator
- Transfer firmware

### Supply firmware file *header.upd*

The most recent firmware for the DP-V1 slave may be found at [www.elco-holding.com.cn](http://www.elco-holding.com.cn) in the service area at "Firmware for system components" as FS200.zip. Within the ZIP file the package file FS200\_Vxxx.zip with xxx=version may be found.

Extract and copy the file *header.upd* into your work directory.

### Load project into hardware configurator

- Open the hardware configurator with the configured DP slave.
- Click on the DP slave and choose **PLC** > *Update Firmware*. This menu option is only available when the highlighted DP slave supports the function "Update firmware".  
→ the dialog window "Update firmware " appears.
- Choose your work directory via the button "Search" where the file *header.upd* is stored. Choose *header.upd*.  
→ You will see information for which modules and from which firmware version on the chosen file is convenient.
- Activate the control field "Activate firmware after loading" because only then the new firmware is copied to the Flash and click then on [Execute].  
→ it is proofed if the chosen file is valid and at positive result the file is transferred to the DP slave.



### Note!

During runtime the firmware update at the DP slave is executed after app. 3s. Please regard that the DP slave executes a reboot, which may cause the DP master to remain in STOP res. may influence your user application.